

**RULES FOR
OKLAHOMA 4-H**

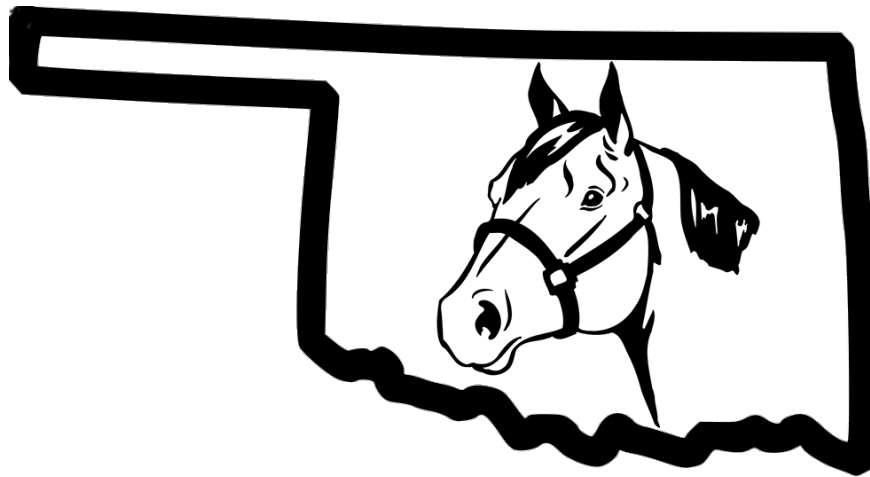

**DISTRICT AND STATE
QUALIFICATION
HORSE SHOWS
2025**



OSU EXTENSION
4-H YOUTH DEVELOPMENT

**RULES FOR OKLAHOMA 4-H
DISTRICT AND STATE
QUALIFICATION HORSE SHOWS**

JANUARY 2025

**This publication supersedes
previous editions of the
Rules for Oklahoma 4-H
District and State Qualification
Horse Shows.**

This handbook of rules is intended to establish uniform regulations and procedures for the district and state 4-H qualification horse shows. Clubs and local groups may have different participation requirements, activities and rules for activities they sponsor and conduct. When the word or emblem signifying "4-H" is used in connection with local shows, events and other activities involving 4-H Horse Project members, those in charge of the show must work closely with local Extension educators to ensure rules for participation and use of symbols, emblems and wording meet general 4-H policies and procedures.

**RULES FOR OKLAHOMA 4-H
DISTRICT AND STATE
QUALIFICATION HORSE SHOWS
TABLE OF CONTENTS**

ROLE OF HORSE SHOWS IN THE 4-H YOUTH DEVELOPMENT PROGRAM	4
RESPONSIBILITIES OF YOUTH IN HORSEMANSHIP EVENTS	4
ELIGIBILITY OF PARTICIPANTS.....	5
QUALIFICATIONS FOR ENTERING DISTRICT AND STATE SHOWS	5
DISTRICT AND STATE SHOW QUALIFYING CLASSES.....	8
GENERAL RULES FOR ALL CLASSES	10
HALTER (CONFORMATION) CLASSES	18
SHOWMANSHIP AT HALTER (Western and English)	19
WESTERN (JUDGED) CLASSES	22
General Rules	22
Western Pleasure	25
Western Horsemanship.....	27
Trail.....	30
Reining.....	34
Ranch Ground Handling.....	53
Ranch Riding	55
Ranch Trail.....	67
Ranch Roping.....	71
Boxing.....	73
TIMED EVENT CLASSES	88
General Rules	88
Barrel Racing.....	89
Pole Bending	91
Stake (Figure 8) Race.....	92
Flag Race.....	95
HUNTER (JUDGED) CLASSES.....	97
General Rules.....	97

Hunter Under Saddle	97
Hunt Seat Equitation	98
Hunter Hack.....	101
Special Clovers Equestrian	102
OTHER 4-H HORSEMANSHIP PROJECT ACTIVITIES.....	104

ROLE OF HORSE SHOWS IN THE 4-H YOUTH DEVELOPMENT PROGRAM

Educational methods of 4-H rely on the experiential learning process. Four-H promotes and sponsors numerous programs and activities designed to encourage youth development through “learning by doing”. This educational model requires that youth solve problems by first attempting an activity, and repeating their attempt to accomplish the skill. The state and district 4-H horse shows are competitive experiences that assist this learning process.

Safely caring for, preparing and exhibiting a horse at horse shows is a long-term process. For most youth, the greatest accomplishments and long term rewards of the program are achieved from the efforts of preparation for competition. Youth development requires 4-H members to seek information from many sources including written and visual educational aids, and the advice and assistance of leaders and horse industry experts.

While assistance is needed to develop skills, it is not intended for others to prepare and care for projects without the involvement and direction of the youth, i.e. fitting, daily care and riding. Those assisting 4-H members in the development of their horse project must participate as an educator that prioritizes the development of youth. Leaders, parents and others influencing the exhibition of the project should make every effort to encourage 4-H members to take the lead role in decision-making, and the handling and care of their project prior to and during exhibitions.

The strength and the survivability of 4-H programs such as horse shows demand everyone’s assistance in encouraging this philosophy. Those directing local 4-H programs should continually emphasize the need for experiential learning through leader, parent and member training, and develop incentive programs that reward those members who excel in self-development.

Although minimal, one clearly enforceable way to promote this philosophy is to require that no one other than the 4-H member is to ride a project horse at any time or location on show grounds at district and state qualifying 4-H horse shows. State and district 4-H horse shows should increase awareness of this need by distributing this and related policies in the entry and show materials. Violation of this policy at district and state qualifying shows can result in disqualification of the 4-H member from the current and future exhibitions associated with the state and district 4-H Horse Program.

RESPONSIBILITIES OF YOUTH IN HORSEMANSHIP EVENTS

The district and state 4-H qualification shows are examples of incentive events conducted to enhance horsemanship abilities of our youth, and by doing so promote positive youth development of life skills. Leadership development, positive character traits, citizenship skills, and a developed sense of need for responsibility of actions, ethical behavior, community involvement and volunteerism are examples of positive life skills. Large amounts of efforts, talents and financial support are necessary for conduct of these events, much of which are supplied from volunteers driven to enhance these traits and abilities in our youth. Conduct of members and associated parties should support the overreaching goals of these events while traveling to and from and during events.

In addition to these goals, these events encourage technical skill development of animal husbandry. The horse project is unique in that it requires a large amount of use skill to be mastered in addition to general production and management skills. The long term value of and short term success at these events requires a 4-H’er to manage and develop their animal as a year-round project. Involvement at events with others places certain responsibilities of preparation of projects.

Horses should be prepared to be exhibited in a healthy state that visually provides the appearance of a sound, healthy, conditioned and non-stressed animal that behaviorally responds positively to the activities, people and other horses at the event. To participate, 4-H’ers should place a self-regulated requirement that their project appears healthy, and behaves safely at events. Above the ability to participate, members should place a self-regulated requirement to be a competitor. Being a competitor requires youth to have a working knowledge of class objectives and the ability to

perform basic skills needed to exceed the minimal requirements for qualified performance in the class. Long-term involvement in preparation and competition should show increases in these technical skills in a step-wise fashion. Done correctly, these experiences should enhance the overriding goal of the 4-H experience to develop positive life skills.

ELIGIBILITY OF PARTICIPANTS FOR DISTRICT AND STATE QUALIFYING SHOWS

1. To be eligible to participate at district and state 4-H qualifying horse shows, youth must be an Oklahoma 4-H member and meet the requirements, including those for enrollment, participation and minimum and maximum age as defined in the Oklahoma 4-H Membership Policy, September 1, 2024-August 31, 2025. Included in the 4-H membership policies are requirements that youth must be a member for 30 days prior to participating in contests beyond county level. For district and state qualifying horse shows, youth must be a member a minimum of 30 days prior to the show **and** a member at time that entry is due. Entry deadline may cause minimum time of membership to be increased beyond 30 days prior to the district show. For youth of minimum age, this requires youth to be 8 years of age and in the 3rd grade and a member of Oklahoma 4-H 30 days prior to the show **and** at time entry is due. This rule applies for district and state qualifying horse shows: County and state fairs, other 4-H sponsored activities, and special events may have different participation requirements.
2. The horse shown at district and state 4-H qualifying shows must be fully owned or leased by the 4-H member, member's parents, brother, sister, guardian, or grandparent at the time of entry deadline and for a minimum of 30 days prior to district show. Specific conditions of lease are established and agreed to by the owner of the horse and the 4-H member and family. Cooperative Extension does not prepare lease agreements. For purposes of use as a 4-H Horse Project, lease agreements should emphasize the same responsibilities as ownership regarding youth's involvement with preparation and care of project horses prior to and during exhibitions. A copy of the written lease agreement must be made available when requested by Cooperative Extension personnel and/or district and state 4-H Horse Show management committees. Ownership proof, i.e. copies of registration papers or lease agreements, should be carried with 4-H projects to district and state 4-H horse shows.
3. The Cooperative Extension Educator with 4-H responsibility in the county where membership is held must verify 4-H membership of the entrant as part of the district show entry process. Entry process for district 4-H horse shows will also require a statement of ownership or lease signed by the 4-H member and parent or guardian to accompany the entry.

QUALIFICATIONS FOR ENTERING DISTRICT AND STATE QUALIFICATION SHOWS

1. Membership and Age requirements: Youth must meet requirements and be enrolled as a member of Oklahoma 4-H (refer to the current year's policy). Refer to the membership policy publication for details on membership requirements not stated within the following category explanations.

Grade divisions between 3rd-5th, 6th-8th and 9th-12th are divided on grade as of September 1st of the competition year. The following grade categories will be used at the district and state qualification shows.

Junior (3rd-5th grades): Must be an Oklahoma 4-H member that is 1) a minimum of 8 years of age and in the third grade by September 1st 2) a member at least 30 days before showing at the district show, and 3) not advanced beyond the 5th grade as of September 1 of the competition year.

Intermediate (6th-8th): Must be an Oklahoma 4-H member that is 1) a member at least 30 days before showing at the district show and at time district entry is due, 2) in the 6th grade and not beyond the 8th grade as of September 1st of the competition year.

Senior (9th- 12th): Must be an Oklahoma 4-H member that is 1) a member at least 30 days before showing at the district show and at time district entry is due, and 2) in the 9th grade as of September 1st of the competition year and have not reached the age of 19 years before September 1 or graduated from 12th grade in the competition year (whichever comes first).

For classes which only have a junior and senior division, Juniors will be 3rd–7th grade, and Seniors will be 8 through 12th grade.

2. For the state and district 4-H qualification classes, each contestant may enter up to three horses. Those horses must be shown and/or ridden by that contestant only. A contestant or a horse cannot enter or show in the same class twice. County and State Fairs, special events and other out of county events may have different horse/rider requirements.
3. A 4-H member and his horse are considered as an entry together. A 4-H member who qualifies for the state show class must exhibit the same horse at state that was used in the district show in that class: In the event of loss of or injury to the qualifying horse, the 4-Her may substitute a horse that was submitted on the horse certification form. The horse certification form must be submitted to the district office **by May 1st**.
4. Horses entering district and state 4-H horse shows must have a current, negative Coggins certificate (dated within 12 months of the respective show) in order to be eligible to show. Coggins certificates will be checked upon arrival to show. Any horse not accompanied with current, negative Coggins certificate will not be allowed to show or be stalled on the show grounds. Adulterating Coggins Certificates or misrepresenting information on certificates are acts governed by Oklahoma State Law and State Department of Agriculture Policies. In addition to actions taken by the state for fraudulent activities, these acts are grounds for restriction of activities in current and future year exhibitions at the district and state 4-H horse shows.
5. Only horses entered in the show are allowed at the district and state show.
6. Stallions, nursing foals or mares with unweaned foals are not to be shown at district or state 4-H horse shows.
7. Participants qualify for a state show class by exhibiting at the district show and completing a qualifying run/class in the class entered at the district show. Only classes entered at the district show may be entered for the state show.
8. Each state may send entries to the Southern Regional 4-H Horse Championships. The state's entries are certified and forwarded by the State Extension Horse Specialist. All exhibitors wanting to compete in the regional championships must turn in a regional entry form with appropriate fees prior to leaving the state show.

DISTRICT AND STATE SHOW QUALIFYING CLASSES

1. A minimum entry requirement of ten horses has been established for the halter and performance classes at the State Show. If the minimum number of horses is not present, different age divisions of a class may be combined. Utilization of this rule at district level will be left to the discretion of the district show management.
2. District and state shows may provide additional/special awards at the discretion of the show committee to encourage accomplishment of 4-H goals, i.e. sportsmanship, character, leadership, proper husbandry practices, etc. At the discretion of the show committee, the shows may also award those earning points in several classes. It is optional for shows to present overall awards. One suggested structure for overall awards includes all or part of the following: Grand/Reserve Champion Halter Gelding/Mare, Performance Divisional Awards (i.e. Speed, Hunter, Western Events) in the different age groups (points accumulated under same system as regional qualification, number 5 above). Awards to be accumulated on a one-horse-one-rider basis, and points accumulated on different horses not to be combined. Points accumulated in combined age classes are to be included in the contestant's respective age group. Ties will be broken on the following steps: a.) Entry earning points in greatest number of classes in that division. b.) Entry placing over the greatest number of contestants. c.) Entry with the greatest number of first place awards. d.) Flip of a coin for awards.
3. The following age categories will be used at the district and state qualification shows. Refer current year's Oklahoma 4-H Membership Policy, September 1, 2024– August 31, 2025 for details on membership requirements not stated within the following category explanations.

Juniors (3rd-5th): Must be a 4-H member that is 1) a minimum of 8 years of age and in third grade as of September 1st of the competition year 2) a member at least 30 days before showing at the district show, and 3) no older than 11 years of age before January 1 of the competition year.

Intermediate (6th-8th): Must be a 4-H member that is 1) a member at least 30 days before showing at the district show and at time district entry is due, 2) in the 6th grade but not past the 8th grade on September 1 of the competition year.

Senior (9th-12th): Must be an Oklahoma 4-H member that is 1) a member at least 30 days before showing at the district show and at time district entry is due, and 2) in the 9th grade of the competition year and have not reached the age of 19 years or graduated from 12th grade (whichever comes first) on September 1st of the competition year.

For classes which only have a junior and senior division, Juniors will be 3rd –7th grade, and Seniors will be 8 through 12th grade.

Qualifying Class Offerings at District and State 4-H Horse Shows

1. Barrel Race (Junior)
2. Barrel Race (Intermediate)
3. Barrel Race (Senior)
4. Pole Bending (Junior)
5. Pole Bending (Intermediate)
6. Pole Bending (Senior)
7. Stakes (Figure 8) Race (Junior)
8. Stakes (Figure 8) Race (Intermediate)
9. Stakes (Figure 8) Race (Senior)
10. Flag Race (Junior)
11. Flag Race (Intermediate)
12. Flag Race (Senior)
13. Halter Mares - 5 yrs. and younger (*Horse's age as of January 1 of competition year*)
14. Halter Mares - 6 yrs. and older (*Horse's age as of January 1 of competition year*)
15. Halter Geldings - 5 yrs. and younger (*Horse's age as of January 1 of competition year*)
16. Halter Geldings - 6 yrs. and older (*Horse's age as of January 1 of competition year*)
17. Showmanship at Halter (Junior)
18. Showmanship at Halter (Intermediate)
19. Showmanship at Halter (Senior)
20. Hunter Under Saddle (Junior)
21. Hunter Under Saddle (Senior)
22. Hunt Seat Equitation (Junior)
23. Hunt Seat Equitation (Senior)
24. Hunter Hack (All Ages)
25. Trail (Junior)
26. Trail (Senior)
27. Western Pleasure (Junior)
28. Western Pleasure (Senior)
29. Western Horsemanship (Junior)
30. Western Horsemanship (Senior)
31. Reining (Junior 3rd-7th grades)
32. Reining (Senior 8th-12th grades)
33. Ranch Horse Riding (Junior 3rd-7th grades)
34. Ranch Horse Riding (Senior 8th-12th grades)
35. Ranch Horse Trail (Junior 3rd-7th grades)
36. Ranch Horse Trail (Senior 8th-12th grades)
37. Ranch Horse Roping (Junior 3rd-7th grades)
38. Ranch Horse Roping (Senior 8th-12th grades)
39. Boxing (Junior 3rd-7th grades)
40. Boxing (Senior 8th-12th grades)
41. Ranch Ground Handling (Junior 3rd-7th grades)
42. Ranch Ground Handling (Senior 8th-12th grades)

GENERAL RULES FOR ALL CLASSES

1. Horses entering district and state 4-H horse shows must have a current negative Coggins certificate (dated within 12 months of the respective show days) in order to be eligible to show. Coggins certificates will be checked upon arrival to show. Any horse not accompanied with current, negative Coggins certificate will not be allowed to show or be stalled on the show grounds.
2. Stallions are not to be shown at district and state shows. No nursing foals or mares with unweaned foals. Only those horses entered at the district or state show are allowed at the show.
3. Unsportsmanlike, irresponsible or misconduct, i.e. illegal, indecent, intimidating, threatening, profane or abusive, by an exhibitor or associated parties at any time during the district or state show on any location on the show grounds are grounds for exhibitor disqualification, suspension from further exhibition and for immediate dismissal of exhibitor and associated parties from the show grounds.
4. Tack and Equipment
 - a. Legal equipment is described in rules governing specific classes. If a qualified person is appointed by the show management, contestants with incorrect equipment should be stopped before competing, as the judge will disqualify contestants with illegal equipment. It is the responsibility of the contestant to check with show officials regarding questionable equipment prior to the start of the class.
 - b. An exhibitor will be excused from the class if there is a tack or equipment breakage that the judge feels is a safety hazard. The exhibitor will not be allowed a rerun if affected by equipment failure or accident to horse or rider.
 - c. The judge or designated show officials have the authority to require the removal or alteration of any piece of equipment which, in his/their opinion is unsafe, tends to give unfair advantage or is deemed inhumane.
 - d. Notice of need for aids for special need youth, including actions needed by assistants, should be provided by the contestant as part of his/her entry material prior to the start of the show. Request for use of aids for special need youth should be accompanied with a medical doctor's statement indicating the need related for use in such activities. Show management should inform the judge and exhibitor as to conditions of use for any such requested aids.
 - e. Use of communication devices, i.e. electronic or radio devices, other than those approved for use by special needs youth, is considered a method to obtain unfair advantage, can be penalized and are grounds for disqualification at the discretion of the judge.
5. The exhibitor will be disqualified for a performance class if their horse falls (shoulder and haunches on same side on ground) and/or if the rider is dismounted from the horse prior to completion of the performance, i.e. judge's placing turned into show management or completion of speed event run.
6. The judge or designated show official has the authority to excuse from competition any horse deemed unsafe and/or out of control. This includes any area or any time while on the show grounds, including times when the entrant is in line-ups or preparation areas for entering the arena for exhibition.
7. Attire:

It is the objective of the 4-H program for exhibitors to be dressed cleanly and neatly. Protective headgear use is encouraged and may be worn in any class without judging discrimination. ASTM/SEI approved safety helmets are strongly recommended for all classes, especially in all speed events. Correct exhibitor number must be visibly worn on the exhibitor or saddle pad in all classes, or exhibitor may be disqualified for that class. Alterations in acceptable attire for special needs youth should be requested by the exhibitor at time of entry, and should be accompanied by a statement from a medical doctor indicated need for use for such activities. Show management should inform the judge and exhibitor as to conditions of use for any such requested alterations.

a. Western Judged and Timed Event Classes.

- i. A western (cowboy) hat or protective headgear (ASTM/SEI approved safety helmets are strongly recommended), which must be on exhibitor's head when exhibitor enters arena. Exception: Show management may make use of a hat optional in speed events. If hat use is declared as optional in speed events, a five second penalty may be assessed if the hat or helmet is not on the exhibitor's person during the time the exhibitor is in the arena. Public announcement of this policy should be made prior to start of speed events.
- ii. Exhibitor number visibly worn by exhibitor or on the saddle pad.
- iii. A shirt with long sleeves, a collar (band, standup, tuxedo, etc.), and shirt tail to be tucked in pants in all classes. Variations such as short sleeves are permitted if covered with a long sleeve jacket.
- iv. Long pants.
- v. Cowboy boots.
- vi. Spurs or chaps are optional. Exception: Not allowed in halter or showmanship classes.
- vii. Gloves are optional in all classes.
- viii. Ball caps, tanks tops, T-shirts or jersey-type shirts are not to be worn.
- ix. See individual division and class rules for exceptions where class specifications indicate otherwise.
- x. Any change from the stated requirements (i - viii above) must be agreed upon by the judges and show superintendent, and announced to contestants prior to start of the class. It is the contestant's responsibility to bring questionable attire to the attention of show management prior to wearing it in any competition, as judge or official may penalize or disqualify contestants who do not conform.

b. Hunter Classes Attire

- i. Hunt coats of traditional hunt seat style and colors such as navy, dark green, grey, black or brown. Maroon and red are improper.
- ii. Breeches or jodphurs of traditional shades of buff, khaki, canary, light gray, or rust.
- iii. High English boots or paddock (jodphur) boots of black or brown.
- iv. Safety helmet of traditional colors (black, navy blue or brown). ASTM/SEI approved safety helmets are strongly recommended. Exhibitors must wear a safety helmet with harness when schooling or exhibiting over fences while on the show grounds.

- v. Hair must be neat and contained (as in a net or braid).
 - vi. Correct exhibitor number must be visibly displayed on exhibitor or on saddle pad.
 - vii. Gloves, spurs (**unrowelled** type that are blunt, round or include a smooth rolling ball) and crops or bats are optional. Exception: Spurs, crops or bats are not allowed in halter or showmanship classes.
 - viii. Any changes from the stated requirements (i-vii above) must be agreed upon by the judges and show superintendent, and announced to contestants prior to class. It is the contestant's responsibility to bring questionable attire to the attention of show management prior to wearing it in any competition, as judge or official may penalize or disqualify contestants who do not conform.
8. *No exhibitor may be tied, buckled or fastened in or on any part of the saddle in any manner or by any means while on show grounds. This includes but is not limited to string, rope, Velcro, rubber bands of any size or strength. Contestants exhibiting as such should be disqualified from the class. Safe, humane animal handling and riding practices are to be prioritized and followed at all times and all places on the show grounds.*
9. Humane Treatment of Animals
- a. No person shall treat any horse in an inhumane manner. This prohibition against inhuman treatment applies to 4-H members and nonmembers.
 - b. Inhumane Treatment of any horse or any other animals on show grounds is strictly prohibited. Treatment of any horse will be considered inhumane if a person, educated or experienced in accepted equine training methods, would perceive the conduct of an individual to be inhumane
 - a. No person shall exhibit any horse that appears to be sullen, dull, lethargic, emaciated, drawn or overly tired. Horses with fresh, bleeding wounds regardless of cause or effect on serviceability should not be exhibited. Judge has authority to penalize or disqualify horses with open wounds.
 - b. Inhumane treatment of a horse identified by the designated officials of the show committee at any time during the district or state show on any location on the show grounds will result in disqualification, dismissal and/or suspensions from further participation at the show.
 - c. The standard by which conduct or treatment will be measured is that which the show management committee rules a reasonable person, informed and experienced in generally accepted training and exhibition procedures, would determine to be cruel, abusive or inhumane. Inhumane treatment includes, but is not limited to,
 - i. placing an object in a horse's mouth to cause undue discomfort or distress
 - ii. leaving a bit in a horse's mouth for extended periods of time to cause undue discomfort or distress
 - iii. tying a horse's head up (above withers), back or around in a stall or anywhere in a manner as to cause undue discomfort or distress
 - iv. tying a horse in a stall without access to food or water for an extended period
 - v. riding or lounging a horse in a manner as to cause undue discomfort or distress to the horse
 - vi. tying or fastening any foreign object onto a horse, halter, bridle, and/or saddle to de-sensitize the horse
 - vii. use of training techniques or methods such as poling or striking a horse's legs with objects
 - viii. excessive spurring or whipping
 - ix. excessive jerking of reins
 - x. excessive fencing or spinning
 - xi. applying excessive pressure on or excessively jerking of a halter lead shank

- xi. use of prohibited equipment, including but not limited to: saw tooth bits, hock hobbles, tack collars, curb strap with tack/rivets or tack hackamores, whips for showmanship, war bridles, riding in a curb bit without a curb strap, wire or solid metal curb straps no matter how padded; wire cavesson, wire or cable tie-downs, bumper bits, metal bosals (no matter how padded); metal loungeing hackamores; chambons; headstalls made of metal, twisted rawhide or rope may not be used on a horse's head (3/8 inch rope may be used with a slip/gag bit or a bonnet); running martingales with curb bits without rein stops; excessively tight cavessons, draw reins attached between or around the front legs; side reins (direct rein from bit to cinch or surcingle).
 - xii. intentional or unintentional inhumane treatment which results in any bleeding, open wound and/or raw area
 - xiii. the use any substance, including but not limited to any type of colorant, dye, glue or hair to hide an injury created by intentional or negligent treatment, prohibited training technique or prohibited equipment
 - ix. any other treatment or conduct deemed by a show official to be inhumane or abusive
- d. Any horse receiving inhumane treatment while entering, showing or exiting a class may be dismissed and/or disqualified from the class upon the discretion of the judge or designated show official, and is grounds for suspension from further exhibition and for immediate dismissal from the show grounds.
10. The State 4-H Horse Advisory Council strongly disapproves of any surgical procedure or injection of any foreign substance or drug which could affect the horse's performance or alter its natural conformation or appearance except for those procedures performed by a duly licensed veterinarian for the sole purpose of protecting the health of the horse. Tails may be lengthened by hair-to-hair attachment only, with no attachments of any kind to the tailbone.
 11. The judge shall check for lameness in all horses brought into any class. The judge has the authority to excuse any horse from the class, due to lameness, at any time while being judged. This is essential regardless of whether or not the competition indicates it is necessary. Obvious lameness shall be cause for disqualification. Obvious lameness is defined as: Consistently observable at a trot under all circumstances; marked nodding, hitching or shorted stride; minimal weight bearing in motion and/or at rest and inability to move.
 12. The judges' decision on conduct and placement of classes shall be in accordance with procedures listed in this publication and are final and not subject to review.
 13. Use of video review: The district and state 4-H horse shows will not be required to facilitate or provide official competition videos but may do so at the direction and discretion of the show management. Judges may request review of an entry's performance via the video provided by an official competition videographer if available, if the class procedure of the class in question requires entries to perform individually, if the judge has reason to believe all horses in all classes requiring individual performance at the show have been videoed, and if the request is initiated by the judge prior to placing of the class. It is at the sole discretion of the judge to request use of video review when available, and this request is not protestable. Use of other sources of video is not to be used by the judge for review of performance or for determining class placing.
 14. An Appeals Committee will be designated by the management before the show begins. This committee is to receive and act upon any protest arising out of any event. A protest must be filed in writing, accompanied with a \$50 cash fee, within one hour of posting of results. If the protest is not upheld by the Appeals Committee, the deposit shall be forfeited to the horse show fund. If upheld, the appeals committee is responsible for directing activities to correct the error, which can include but not limited to refund of entry fee, and correcting any affected placings or misdistribution of awards.
 15. Awards will be presented to the top contestants in the class. If two judges are used to judge the same class (multi-judge system), the class winner will be determined by combining the placings of each judge with the following

guidelines: Each judge places 10 contestants. Those contestants ranking highest on the combined placings of the two judges will be placed over those contestants with lower combined placings of the two judges, with the following conditions: a.) Those contestants placing on both judge's cards will be placed over contestants placing only on a single judge's card, b.) Ties in final rankings will be broken by pre-assigning one of the judges as a tiebreaker for that class.

Class	Required	Optional	Prohibited
Halter and Showmanship at Halter	<p><u>Attire:</u> Western: A western (cowboy) hat or protective headgear. Long pants. Long sleeve shirt or jacket. Cowboy boots. English: A safety helmet, Hunt coat, breeches or jodphurs, high English boots or paddock boots. <u>Equipment:</u> Western: Halter and lead rope (leather preferred) English: Halter and lead rope (leather preferred) or bridle.</p>	<p><u>Attire:</u> Western or English: Gloves, accessories such as scarves, ties.</p>	<p><u>Attire:</u> Ball caps, tank tops, T-shirts, jersey-type shirts. Spurs. Chaps, chinks. <u>Equipment:</u> Crops, bats or whips. Protective boots, bandages or leg wraps, lip chains</p>
Western Pleasure/ Western Riding / Trail	<p><u>Attire:</u> A western (cowboy) hat or protective headgear. Long pants. Long sleeve shirt or jacket. Cowboy boots. <u>Equipment:</u> Western saddle. Western style, curb bit with split reins or a romal with a ½ inch or wider; leather or flat chain chinstrap for any age horse. Or for horses five years of age and younger, a bosal hackamore with split rein or single rein Mecate Or a ring snaffle with split reins.</p>	<p><u>Attire:</u> Gloves, accessories such as scarves, ties. Chaps, Spurs <u>Equipment:</u> Rope, hobbles, tapaderos</p>	<p><u>Attire:</u> Ball caps, tank tops, T-shirts, jersey-type shirts. <u>Equipment:</u> Protective boots, bandages or leg wraps. Wire chinstraps, chin strap narrower than ½ inch, martingales, draw reins, nosebands and tiedowns. No exhibitor may be tied, buckled or fastened in or on any part of the saddle; includes but not limited to string, rope, Velcro, rubber bands of any size or strength.</p>
Western Horsemanship/ Reining	<p><u>Attire:</u> A western (cowboy) hat or protective headgear. Long pants. Long sleeve shirt or jacket. Cowboy boots. <u>Equipment:</u> Western saddle. Western style, curb bit with split reins or a romal with a ½ inch or wider leather or flat chain chinstrap for any age horse. Or for horses five years of age and younger, a bosal hackamore with split rein or single rein Mecate or a ring snaffle with split rein.</p>	<p><u>Attire:</u> Gloves, accessories such as scarves, ties. Chaps, Spurs <u>Equipment:</u> Rope, hobbles, tapaderos. Protective boots, bandages or leg wraps.</p>	<p><u>Attire:</u> Ball caps, tank tops, T-shirts, jersey-type shirts. <u>Equipment:</u> Wire chinstraps, chin strap narrower than ½ inch, martingales, draw reins, nosebands and tiedowns. No exhibitor may be tied, buckled or fastened in or on any part of the saddle; includes but not limited to string, rope, Velcro, rubber bands of any size or strength.</p>
Ranch Horse Division Ranch Riding Ranch Trail Ranch Roping Boxing Ranch Ground Handling	<p><u>Attire:</u> A western (cowboy) hat or protective headgear. Long pants. Long sleeve shirt or jacket. Cowboy boots. <u>Equipment:</u> Western saddle. Western style, curb bit with split reins or a romal with a ½ inch or wider; leather or flat chain chinstrap for any age horse; horses of any age can be ridden in a legal snaffle bit or a bosal hackamore with split rein or single rein Mecate or a ring snaffle with split reins <u>or mecate</u>. Roping reins may be used in Junior Ranch Roping. Horses ridden in a curb bit must be ridden one handed.</p>	<p><u>Attire:</u> Gloves, accessories such as scarves, ties. Chaps, Spurs Breast collars and rear cinches are encouraged; rope or riata (if used must be coiled or attached to the saddle); tapaderos; hobbles attached to the saddle; protective leg boots; trimming bridle path, fetlocks or excessive facial hair</p>	<p>No hoof polish, braided or banded manes or tail extensions <u>Attire:</u> Ball caps, tank tops, T-shirts, jersey-type shirts. <u>Equipment:</u> Wire chinstraps, chin strap narrower than ½ inch, martingales, draw reins, nosebands and tiedowns. No exhibitor may be tied, buckled or fastened in or on any part of the saddle; includes but not limited to string, rope, Velcro, rubber bands of any size or strength. Discouraged: Trimming inside ears; silver on bridles and saddles</p>

Hunter Under Saddle/Hunter Hack	<p>Attire: Hunt coat, breeches or jodphurs, High English boots or paddock boots, safety helmets. ASTM/SEI certified helmet required for Hunter Hack.</p> <p>Equipment: Forward seat (hunt) saddle. English snaffle (no shank), kimberwick, Pelham or full bridle. Cavesson noseband and plain leather brow band bridle.</p>	<p>Attire: Gloves, unrowelled type spurs, crops or bats.</p> <p>Equipment: English breast plate, braiding of mane or tail in hunt style, rubber reins and unrowelled slip on spurs</p>	<p>Equipment: Draw reins, rowelled spurs, standing or running martingales, figure 8 or flash cavessons, protective boots, leg wraps and bandages: Exception: protective boots, leg wraps and bandages allowed at discretion of judge for use outdoors during inclement weather in hunter hack. No exhibitor may be tied, buckled or fastened in or on any part of the saddle; includes but not limited to string, rope, Velcro, rubber bands of any size or strength.</p>
Hunter Seat Equitation	<p>Attire: Hunt coat, breeches or jodphurs, High English boots or paddock boots, safety helmets. ASTM/SEI certified helmet required for Hunter Hack.</p> <p>Equipment: Forward seat (hunt) saddle. English snaffle (no shank), kimberwick, Pelham or full bridle. Cavesson noseband and plain leather brow band bridle.</p>	<p>Attire: Gloves, unrowelled type spurs, crops or bats.</p> <p>Equipment: English breast plate, braiding of mane or tail in hunt style, rubber reins and unrowelled slip on spurs, protective boots, leg wraps and bandages are allowed.</p>	<p>Equipment: Draw reins, rowelled spurs, standing or running martingales, figure 8 or flash cavessons. No exhibitor may be tied, buckled or fastened in or on any part of the saddle; includes but not limited to string, rope, Velcro, rubber bands of any size or strength.</p>
Barrels, Pole Bending, Stakes Race, Flag Race	<p>Attire: A western (cowboy) hat or protective headgear. Long pants. Long sleeve shirt or jacket. Cowboy boots.</p> <p>Equipment: Western saddle. The use of any mechanical hackamore or any type of bridle; however the judge or show committee may prohibit the use of bits or equipment that they consider severe. Closed reins recommended for all bridles.</p>	<p>Attire: Gloves, accessories such as scarves, ties. Chaps, Spurs</p> <p>Equipment: Tie downs, nose bands, running martingales, protective leg wraps and bandages, whip, crop or bat.</p>	<p>Attire: Ball caps, tank tops, T-shirts, jersey-type shirts. Spurs. Chaps, chinks.</p> <p>Equipment: Wire chin straps, chin straps narrower than ½ inch, tie down with bare metal in contact with horse's head, chain, wire or metal tie down no matter how covered or padded. No exhibitor may be tied, buckled or fastened in or on any part of the saddle; includes but not limited to string, rope, Velcro, rubber bands of any size or strength.</p>

HALTER (CONFORMATION) CLASSES

Halter class is defined as a class where the horse is judged based upon its conformation. Conformation is defined as physical appearance resulting from the arrangement of muscle, bone and other body tissues. Rating conformation depends upon objective evaluation of a **well-mannered horse** with appropriate breed and sex characteristics, balance, structural correctness, refinement, degree of muscling and movement. Balance is the single most important characteristic among all breeds. Balance relates how well the size and shape of the various body parts blend together, and is influenced almost in entirety by skeletal structure. Skeletal structure refers to the proper shape and alignment of bones so movement and the potential for performance is increased. Breed characteristics allow for different emphasis of the remaining traits, as some breeds are naturally more muscled than others. Refinement mainly refers to the shape, trimness, and attachment of the head and neck. Muscling refers to both the quantity and appearance of muscle. Conformation is one of the largest influences to performance; as such halter class standards should stress the relationship of conformational attributes that enhance athletic performance.

1. Horses should walk to the judge one at a time. As the horse approaches, the judge will step to the right to enable the horse to trot straight past. At a marker, the horse should, turn to the left and *continue to trot* and line up for individual inspection at the direction of a ring steward. After trotting, horses will be lined up head to tail for individual inspection by the judge. The judge should inspect each horse from both sides, front and rear.

2. All horses showing in conformation should be individually inspected for conformational standards and evaluated for quality of movement. Lameness and unsoundness shall be cause for disqualification. Movement quality should be accessed at a walk and trot, and it is desirable to observe movement from the side as well as from the front and rear.
3. The procedures, tack and attire outlined for the showmanship at halter class should serve as guide for fitting and showing a horse in the halter class. The judge or designated show officials have the authority to require the removal or alteration of any piece of equipment which, in his/their opinion is unsafe, tends to give unfair advantage or is deemed inhumane. Use of lip chains is prohibited.
4. A well-mannered horse is a horse that (1) is under control by the exhibitor while tracking and standing for inspection and (2) is reasonably still and flat-footed while standing for inspection.
5. Judges may dismiss horses from the class that exhibit disruptive behavior: including, but not limited to, rearing, striking, biting, backing or falling into others. Judges should disqualify and excuse from the ring prior to final placing a horse that: *a.* exhibits disruptive behavior such that it or other horses are unable to be inspected by the judge, *b.* exhibits disruptive behavior such that the safety of it, the handler, an exhibitor, a judge or another horse is endangered, *c.* is not under control of the exhibitor, *d.* becomes detached from the exhibitor, or *e.* has fallen and is on its side with all four feet extended in the same direction. Rather than disqualify, a judge may choose to fault a horse that is exhibiting disruptive behavior so long as such disruptive behavior does not qualify as behaviors described in a through e above. The decision of the judge on these matters is final.
6. A horse with observable blood on its body, including, but not limited to, the nose, chin, mouth, tongue, or gums, regardless of cause, and horses judged as lame (item 11, general rules) should be excused/disqualified from the class.

SHOWMANSHIP AT HALTER

(Western and English Combined)

The showmanship class shall be designed to evaluate the exhibitor's ability to execute, in concert with a well-groomed and conditioned horse, a set of maneuvers prescribed by the judge with precision and smoothness while exhibiting poise and confidence, and maintaining a balanced, functional and fundamentally correct body position. It is mandatory that the judge post any pattern(s) to be worked at least one hour prior to the commencement of the class. Pattern(s) should be designed to test the showman's ability to effectively present a horse to the judge. All ties will be broken at the judge's discretion.

1. Class Procedures
 - a. All exhibitors may enter the ring and then work individually, or each exhibitor may be worked from the gate individually. The following maneuvers are considered acceptable: lead the horse at a walk, jog, trot or extended trot, or back in a straight or curved line, or a combination of straight and curved lines; stop; and turn 90 (1/4), 180 (1/2), 270 (3/4), 360 (full turn) degrees or any combination or multiple of these turns. Handlers should be on the left of the horse when leading and executing turns unless specified to be on the right by the pattern or judge's instructions. Handlers should not be positioned directly in front of the horse while performing any of the maneuvers.
 - b. The judge must have exhibitors set the horse up for inspection sometime during the class.
2. Appearance of the Horse/Tack.
 - a. The horse's body condition and overall fitness should be assessed. The hair coat should be clean, well brushed, and in good condition. The mane, tail, forelock, and wither tuft may not contain ornaments (ribbons, bows, etc.), but may be braided or banded for English or Western. The length of mane and tail may vary, if they are neat,

clean and free of tangles. The mane should be even in length or may be roached, but the forelock and tuft over the withers must be left. The bridle path, eyebrows, and long hair on the head and legs may be clipped. Hooves should be properly trimmed and if shod, the shoes should fit correctly and clinches should be neat. Hooves must be clean, may be painted black with hoof dressings, or shown naturally.

- b. Tack should fit properly, be neat, clean and in good repair. Clean, adjusted and acceptable bridle or halter is allowed for showing with English attire. Clean, adjusted halter to fit the horse is allowed with Western attire. Crops, bats or whips prohibited. Protective boots, bandages or leg wraps are prohibited. The judge or designated show officials have the authority to require the removal or alteration of any piece of equipment which, in his/their opinion is unsafe, tends to give unfair advantage or is deemed inhumane.

3. Appearance of the Exhibitor.

- a. Exhibitors may show in Western or English attire as appropriate for the respective disciplines. Clothes and person are to be neat and clean. (See attire statements in the 'General Rules for All Classes' section.)
- b. Exhibitors should be poised, confident, courteous, and genuinely sportsmanlike at all times, quickly recognizing and correcting faults in the positioning of the horse. The exhibitor should continue showing the horse until the class has been placed or they have been excused, unless otherwise instructed by the judge. The exhibitor should appear business-like, stand and move in a straight, natural and upright manner, and avoid excessive, unnatural, or animated body positions.
- c. The exhibitor must lead on the horse's left side holding the lead shank in the right hand near the halter with the tail of the lead **loosely** coiled in the left hand unless requested by the judge to show the horse's teeth. It is preferable that the exhibitor's hand not be on the snap or chain portion of the lead continuously. The excess lead should never be **tightly** coiled, rolled or folded. When leading, the exhibitor should be positioned between the eye and the mid-point of the horse's neck, referred to as the leading position.
- d. Both arms should be bent at the elbow with the elbows held close to the exhibitor's side and the forearms held in a natural position. Height of the arms may vary depending on the size of the horse and exhibitor, but the arms should never be held straight out with the elbows locked.
- e. The position of the exhibitor when executing a turn to the right is the same as the leading position with the exhibitor on the left side, except that the exhibitor should turn and face toward the horse's head and have the horse move away from them to the right. The exhibitor should not be positioned directly in front of the horse while turning.
- f. When executing a back, unless specified to be on the right side by the pattern or judge's instructions, the exhibitor should turn from the leading position on the left of the horse so to face toward the rear of the horse with the right hand extended across the exhibitor's chest and walk forward beside the horse with the horse moving backward. The exhibitor should not be positioned directly in front of the horse while backing.
- g. When setting the horse up for inspection, the exhibitor should stand angled toward the horse in a position between the horse's eye and muzzle and should never leave the head of the horse. It is recommended, but not mandatory, that exhibitors use the "Quarter Method" when presenting the horse. The exhibitor should maintain a position that is safe for themselves and the judge. The position of the exhibitor should not obstruct the judge's view of the horse and should allow the exhibitor to maintain awareness of the judge's position at all times. The exhibitor should not crowd other exhibitors when setting up side-by-side or head-to-tail. When moving around the horse, the exhibitor should change sides in front of the horse with minimal steps and should assume the same position on the right side of the horse that they had on the left side.
- h. Leading, backing, turning, and initiating the set up should be performed from the left side of the horse. At no time should the exhibitor ever stand or lead directly in front of the horse. The exhibitor should not touch the horse with their hands or feet, or visibly cue the horse by pointing their feet at the horse during the set up. The exhibitor

should not change hand location on the lead unless asked to show the horse's teeth or specifically instructed to do so by the pattern or judge's instructions.

4. Performance.

- a. The exhibitor should perform the work accurately, precisely, smoothly, and with a reasonable amount of speed. Increasing speed of the work increases the degree of difficulty; however, accuracy and precision should not be sacrificed for speed. The horse should lead, stop, back, turn, and set up willingly, briskly and readily with minimal visible or audible cueing. Faults and disqualifications are outlined below.
- b. The horse's path should position the horse directly to and away from the judge when moving in a straight line and track briskly and freely at the prescribed gait as instructed. The horse's head and neck should be straight and aligned with its body.
- c. The stop should be straight, prompt, smooth and responsive with the horse's body remaining straight.
- d. The horse should back up readily with the head, neck and body aligned with the path of movement.
- e. The handler should be on the left and the horse should be turned to the right, with the horse pivoting on the right hind leg while stepping the left front leg across and in front of the right front leg. An exhibitor should not be penalized if their horse performs a pivot on the left hind leg, but an exhibitor whose horse performs an ideal pivot should receive more credit. The pattern may specify handlers turn when positioned on the right of the horse with direction of turn also identified.
- f. The horse should be set up quickly with the feet squarely positioned as characteristic of breed showing standards for halter. The exhibitor does not have to reset a horse that stops squarely.

5. Scoring. Exhibitors are to be scored from 0 to infinity, 70 denoting an average performance. Patterns will be divided into maneuvers and each maneuver will be scored from +3 to -3 with ½ point increments allowed. Maneuver scores should be determine independent of penalties.

SCORING SYSTEM: One-half point increments are acceptable. Run content scores will be indicated as follows:

+3 = Excellent

+2 = Very Good

+1 = Good

0 = Correct

-1 = Poor

-2 Very Poor

-3 = Extremely Poor

Exhibitors overall showmanship form and effectiveness should also be scored from 0 to 5 with 0-1 average, 2-3 good, 4 very good and 5 excellent.

Penalties. Maneuver application and penalties are to be scored independently. The following penalties will be applied for each occurrence and will be deducted from the final score:

a. Three (3) points:

- break of gait at walk or jog/trot for 2 strides
- over or under turning up to 1/8 of a turn
- ticking or hitting cone
- sliding a pivot foot
- lifting a pivot foot during a pivot and replacing in same place

b. Five (5) points:

- not performing gait or not stopping within 10 feet of designated area
- break of gait at walk or jog/trot for more than 2 strides
- splitting the cone (cone between horse and handler)
- horse stepping out of or moving the hind end significantly during a pivot or turn
- horse stepping out of set-up after presentation
- over/under turning 1/8 to ¼ of designated turn
- Resting a foot or hipshot in a setup

c. Ten (10) points.

- Out of position during inspection
- exhibitor touching the horse or kicking or pointing their feet at the horse's feet during set up
- standing directly in front of the horse
- loss of lead shank or holding chain or two hands on shank
- Blatant disobedience including biting, kicking, rearing or pawing; horse continually circling exhibitor

d. Off pattern (OP) Exhibitors must always place below exhibitors not incurring a fault(s). Judge shall include any appropriate penalties and OP in the penalty box for each occurrence. The judge shall place exhibitors with one (1) OP above an exhibitor with two (2) OP s regardless of the score

- *going off pattern*
- *knocking over or on wrong side of cone*
- *never performing specified gait*
- *under/overturning more than ¼ turn than designated*

6. The judge or designated show officials have the authority to require the removal or alteration of any piece of equipment which, in his/their opinion is unsafe, tends to give unfair advantage or is deemed inhumane. Use of lip chains is not allowed in showmanship at halter and should result in disqualification.
7. A horse with observable blood on its body, including, but not limited to, the nose, chin, mouth, tongue, or gums, regardless of cause, and horses judged as lame (item 11, general rules) should be excused/disqualified from the class.
8. Disqualifications (should not be placed) include: Judges may dismiss horses from the class that exhibit disruptive behavior: including, but not limited to, rearing, striking, biting, backing or falling into others. Judges should disqualify and excuse from the ring prior to final placing a horse that: a. exhibits disruptive behavior such that it or other horses are unable to be inspected by the judge, b. exhibits disruptive behavior such that the safety of it, the handler, an exhibitor, a judge or another horse is endangered, c. is not under control of the exhibitor, d. becomes detached from the exhibitor, or e. has fallen and is on its side with all four feet extended in the same direction. Failure of exhibitor to wear correct number in a visible manner; willful abuse; excessive schooling or training or use of artificial aids is also grounds for disqualification.

WESTERN JUDGED DIVISION CLASSES

General Rules

1. In all western classes, horses will be shown in a western saddle. A western saddle is a common type of saddle distinguished by a large noticeable fork on which there is some form of horn, a high cantle and large skirts. Silver equipment will not count over a clean, working outfit in good repair. Horses five years old and younger may be shown in a snaffle bit, hackamore, or western style curb bit. Horses six years old and older may only be shown in a western-style, curb bit, except in the Ranch Division.

2. Western-style, curb bit means the bit has shanks, a solid or broken mouthpiece, and acts with leverage. Curb bits must be free of mechanical device and should be considered a standard western bit. Chain or leather chin straps are required when using curb bits, but must meet the approval of the judge, be at least one-half inch in width and lie flat against the jaw of the horse.
 - a. Curb bits shanks may be fixed or loose; however, slip or gag bits are not acceptable. Maximum allowable shanks length of 8 1/2" from the inside of the top of the headstall ring on the upper shank to the bottom of the rein ring on the lower shank.
 - b. Curb bits may have a solid or broken mouthpiece. Mouthpiece bars should be round, oval or egg shaped, smooth and unwrapped metal of 5/16" to 3/4" in diameter, measured 1" from the cheek. They may be inlaid, but must be smooth or latex wrapped. Broken mouthpieces may be two or three pieces. A three-piece, connecting ring of 1 1/4" or less in diameter, or a connecting flat bar of 3/8" to 3/4" (measured top to bottom with a maximum length of 2"), which lies flat in the horse's mouth is acceptable. The port of curb bit mouthpieces must be no higher than 3 1/2" maximum, rollers and covers are acceptable. Slip or gag bits (mouthpiece constructed so it moves up and down the shank when rein pressure is applied), and donut and flat polo mouthpieces are not acceptable. Nothing may protrude below the mouthpiece, such as extensions or prongs, including upward prongs on solid mouthpieces.
3. When using curb bits, only one hand may be used on the reins and the hand must not be changed (except in order to negotiate obstacles in Trail). The hand is to be around the reins; index finger only between split reins is permitted. Violation of this rule is a disqualification. Excess reins may be straightened or disentangled anytime during the class, as long as the free hand remains behind the rein hand.

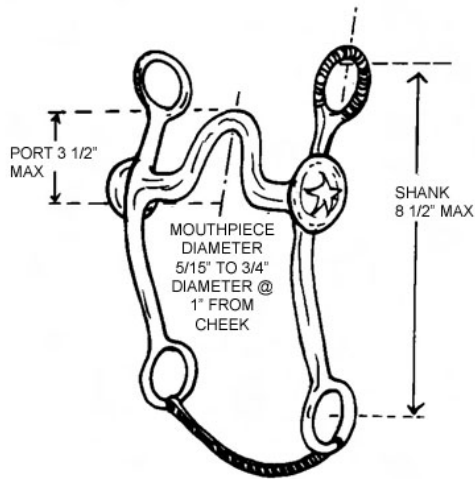

4. Split reins are mandatory for curb bits in western judged classes unless using a romal. A romal may be used with a western style curb, but the romal shall not be used forward of the cinch or to signal or cue the horse in any way. The judge shall severely penalize violation of this rule.
 - a. A romal is an extension of braided material attached to closed reins. The extension shall be carried in the free hand with a 16-inch space between the reining hand and the free hand holding the romal. When using the romal, the rider's hand shall be around the reins, the thumb on top and the fingers closed lightly around the reins with no fingers between the reins.

- b. The free hand can be used to adjust the length of rein on a romal in all classes with the exception of the reining class (See reining rules for clarification). In the reining class, using the hand holding the romal to alter the tension or length of the reins from the bridle to the reining hand is considered to be the use of two hands and a score of 0 will be applied, with the exception of any place a horse is allowed to be completely stopped during a pattern.
5. The hackamore (bosal) is permitted in western judged classes for horses five years of age and younger and in the Ranch Division. Hackamore means that a horse will be ridden only with a rawhide braided, leather or rope bosal, the core of which may be either rawhide or flexible cable. Absolutely no rigid material will be permitted under the jaws, regardless of how padded or taped. Horse hair bosals are prohibited. Mechanical hackamores are prohibited in western judged classes. Horses are to be shown in standard, plain, or silver headstalls. Standard, leather or woven, split reins are mandatory with bits. Split reins or single rein Mecates are permitted with hackamores: Two-hands are to be used on the reins when using a hackamore. When using split reins, the tails of the reins should be crossed on opposite sides of the neck.
6. Only horses five years of age or younger, *except for the Ranch Division*, may be shown with a ring snaffle in all western division classes in accordance with the following rules:
 - a. Snaffle means the conventional O-ring, egg-butt or D-ring with a ring no larger than 4". The mouthpiece should be round, smooth and unwrapped metal. It may be inlaid, but smooth or latex-wrapped. The bars must be a minimum of 5/16" in diameter, measured one inch in from the cheek with a gradual decrease to center of the snaffle. The mouthpiece may be two or three pieces. A three-piece, connecting ring of 1 1/4" or less in diameter, or a connecting flat bar of 3/8" to 3/4" (measured top to bottom, with a minimum length of 2") that lies flat in the horse's mouth is acceptable.
 - b. The rings must be free of rein, curb or headstall attachments, which would provide leverage. Optional curb strap attached below the reins on a snaffle bit is acceptable. Chain curb straps are not permitted with a western snaffle bit.
 - c. Horses are to be shown in standard, plain, or silver headstalls. Standard, leather or woven, split reins are mandatory with snaffle bits. **Split reins are to be used with snaffles, two hands on the reins, the tails of the reins crossed on opposite sides of the neck.** Closed reins may not be used with a snaffle bit, except in reining, boxing, where a mecate is permitted.
7. Optional equipment for western judged classes includes:
 - a. Rope or riata (coiled and attached to saddle).
 - b. Hobbles attached to saddle.
 - c. Tapaderos.
 - d. Protective boots, bandages or leg wraps, (except in Western Pleasure, Showmanship, Halter, Trail and Western Riding, where they are not allowed).The use of slip on (easy care) horse boots or related footwear are not considered as protective boots and are permissible to be worn in all classes.
 - e. Spurs in riding classes (not to be used forward of the cinch).
 - f. Chaps in riding classes.
8. Prohibited equipment includes:
 - a. Wire chinstraps, regardless of how padded or covered.
 - b. Any chin strap narrower than one-half inch.

- c. Martingales, draw reins, nosebands and tie-downs
 - d. Protective boots, bandages or leg wraps in Western Pleasure, Showmanship, Halter, Trail and Western Riding.
 - e. No exhibitor may be tied, buckled or fastened in or on any part of the saddle in any manner or by any means while on show grounds. This includes but is not limited to string, rope, Velcro, rubber bands of any size or strength. Contestants exhibiting as such should be disqualified from the class.
9. Attire: It is the objective of the 4-H program for exhibitors to be dressed cleanly and neatly. Protective headgear is strongly encouraged and may be worn in any class without judging discrimination. Alterations in acceptable attire for special needs youth should be requested by the exhibitor at time of entry, and should be accompanied by a statement from a medical doctor indicated need for use for such activities. Show management should inform the judge and exhibitor as to conditions of use for any such requested alterations.
- a. A western (cowboy) hat or protective headgear (ASTM/SEI approved safety helmets are strongly recommended), which must be on exhibitor's head when exhibitor enters arena. Exception: Show management may make use of a hat optional in speed events. If hat use is declared as optional in speed events, a five second penalty will be assessed if the hat or helmet is not on the exhibitor's person during the time the exhibitor is in the arena. Public announcement of this policy should be made prior to start of speed events.
 - b. Exhibitor number visibly worn by exhibitor or on the saddle pad.
 - c. A shirt with long sleeves, a collar (band, standup, tuxedo, etc.), and shirt tail to be tucked in pants in all classes. Variations such as short sleeves are permitted if covered with a long sleeve jacket.
 - d. Long pants.
 - e. Cowboy boot.
 - f. Spurs or chaps are optional. Exception: Not allowed in halter or showmanship classes.
 - h. Gloves are optional in all classes.
 - i. Ball caps, tanks tops, T-shirts or jersey-type shirts are not to be worn.
 - j. See individual division and class rules for exceptions where class specifications indicate otherwise.
 - k. Any change from the stated requirements (a-j above) must be agreed upon by the judges and show superintendent, and announced to contestants prior to start of the class. It is the contestant's responsibility to bring questionable attire to the attention of show management prior to wearing it in any competition, as judge or official may penalize or disqualify contestants who do not conform.

WESTERN PLEASURE

1. Refer to Western Judged Division General Rules for acceptable tack, attire and equipment.
2. This class will be judged on the performance of the horse at the discretion of the judge. Quality of movement of the walk, jog, moderate extended jog, lope and back-up will follow descriptions outlined in The Official Handbook of Rules and Regulations of AQHA. Horses should be shown with control on a reasonably loose rein. A good pleasure horse has a free-flowing stride of reasonable length in keeping with his conformation. He should cover a reasonable amount of ground with little effort. Ideally, he should have a balanced, flowing motion, while exhibiting correct gaits that are of the proper cadence. The quality of the movement and the consistency of the gaits are major considerations. He should

carry his head and neck in a relaxed, natural position, with his poll level with or slightly above the level of the withers. He should not carry his head behind the vertical, giving the appearance of intimidation, or be excessively nosed out, giving a resistant appearance. His head should be level, with the nose slightly in front of the vertical, having a bright expression with his ears alert. He should be responsive yet smooth in transitions. When asked to extend, he should move out with the same flowing motion. Maximum credit should be given to the flowing, balanced and willing horse that gives the appearance of being fit and a pleasure to ride.

- A. Correctness-Concerning correctness, which is the most important element of the hierarchy, judges must assess if the exhibitor has performed each gait correctly as defined during all or the majority of all of the class in order to have a correct or positive evaluation. For western gaits, this includes a four-beat walk, two-beat jog and three-beat lope. The distinctness of the designated cadence for the gait being performed is essential.
 - B. Quality-Concerning quality, which is the second most important element in the hierarchy, and can only be considered positively if the gait performance has complied with the first element of correctness. When evaluating the pleasing characteristics of a gait, among many considerations, judges must consider overall gracefulness, relaxed expression, topline, softness of movement, consistency and length of stride of the designated gait.
 - C. Degree of Difficulty-Concerning degree of difficulty, this is the least important and last element of the hierarchy. This element must only be considered if the requirement for correctness has been met and combination of correctness and quality allow the performance to be considered for placement. Difficulty is greatly influenced by exhibiting a pleasure horse at a pace and speed that allows for correctness and best quality of a gait for that individual.
 - D. A performance of a walk that is ground covering and free flowing has a high degree of difficulty. A jog or lope that is performed with a slow rhythm without sacrificing correctness or quality has a high degree of difficulty. Slowness that sacrifices correctness or negatively impacts quality shall be considered incorrect and a poor performance at best.
3. Horses are shown at a walk, jog and lope on a reasonable loose rein without undue restraint. Horses ridden with two hands are to be ridden with light contact. Horses must work both ways of the ring at all three gaits to demonstrate their ability with different leads. Horses may be required to reverse at the walk or trot and may be required to go from any gait to any other gait at the discretion of the judge. At the option of the judge, horses may be asked to lengthen their stride at the walk or lope, one or both ways of the ring. An extended jog is a definite two-beat lengthening of stride and covering of more ground. Riders should sit the extended jog. Cadence and balanced stride with smoothness is more important than speed.
 4. All or only horses in finals may be asked to back.
 5. Horses are to be reversed to the inside of the arena.
 6. For safety of the contestants, a reverse at the lope or extended lope shall not be called.
 7. Large numbers in this class will necessitate elimination heats to accommodate all horses. The suggested maximum number is 25 horses in each heat.
 8. Any portion of a class or heat may be placed on the rail for extra work by the judge at any time.
 9. At no time shall the fault out system be used that results in a contestant being eliminated individually. Instead, a more positive approach should be used with winners being announced and remainder of the class being dismissed from the arena as a group.
 10. Faults to be penalized include wrong leads, excessive speed, breaking gait, excessive slowness, slow transitions, touching the horse or saddle with the free hand, head carriage too high or too low, nosing out, over flexing, opening the mouth, stumbling, short, choppy strides, excessive motion of the topline, tight reins, or excessively long reins.

11. Judge has the authority to excuse and/or disqualify any horse deemed unsafe or out of control. Fall of horse and/or rider falling off horse results in disqualification. An exhibitor will be excused from the class (disqualified) if there is a tack or equipment breakage that the judge feels is a safety hazard.

WESTERN HORSEMANSHIP

1. General Rules
 - a. Refer to Western Judged Division General Rules for acceptable tack, attire and equipment.
 - b. The western horsemanship class is designed to evaluate the rider's ability to execute, in concert with their horse, a set of maneuvers prescribed by the judge with precision and smoothness while exhibiting poise and confidence, and maintaining a balanced, functional and fundamentally correct body position. The ideal horsemanship pattern is extremely precise with the rider and horse working in complete unison, executing each maneuver with subtle aids and cues. The horse's head and neck should be carried in a relaxed, natural position, with the poll level with or slightly above the withers. The head should not be carried behind the vertical, giving the appearance of intimidation, or be excessively nosed out, giving a resistant appearance.
 - c. It is mandatory that the judge post pattern(s) to be worked at least one hour prior to the commencement of the class. Pattern(s) should be designed to test the horseman's ability. All patterns must include a walk, jog, lope and a back. Judge may ask for additional work of the exhibitors for the final placing. All ties will be broken at the judge's discretion.
2. Class Procedures.
 - a. All exhibitors must enter the ring and then work individually, or each exhibitor may be worked from the gate individually. When exhibitors are worked individually from the gate, a working order is required. Exhibitors should be instructed to either leave the arena, fall into line, or fall into place on the rail after their work. The whole class, or just the finalists must work at all three gaits at least one direction of the arena.
 - b. The following maneuvers are acceptable in a pattern: walk, jog, trot, extended trot, lope, or extended lope in a straight line, curved line, serpentine, circle, or figure 8, or combination of these gaits and maneuvers; stop; back in a straight or curved line; turn or pivot, including spins and rollbacks on the haunches and/or on the forehand; side pass, two track, or leg yield; flying or simple change of lead; counter canter; or any other maneuver; or ride without stirrups. When a lead change is a required maneuver, it may be designated as a simple change or the exhibitor has the option to perform either a simple or flying lead change. Judges should not ask exhibitors to mount or dismount.
3. Overall Appearance of Exhibitor and Horse: The exhibitor's overall poise, confidence, appearance, and position throughout the class as well as the physical appearance of the horse will be evaluated.
 - a. Appropriate western attire must be worn, see the attire section in general rules for Western Judged classes. Clothes and person are to be neat and clean. The use of any artificial aid or magnetic device will result in disqualification.
 - b. The exhibitor should appear natural in the seat and ride with a balanced, functional, and correct position regardless of the maneuver or gait being performed. During the rail work and pattern the exhibitor should have strong, secure, and proper position. Exhibitors should sit and maintain an upright position with the upper body at all gaits. The rider should sit in the center of the saddle and the horse's back with the legs hanging to form a straight line from the ear, through the center of the shoulder and hip, touching the back of the heel or through the ankle. The heels should be lower than the toes, with a slight bend in the knee and the lower leg should be

directly under the knee. The rider's back should be flat, relaxed, and supple. An overly stiff and/or overly arched lower back will be penalized. The rider's base of support should maintain secure contact with the saddle from the seat to the inner thigh. Light contact should be maintained with the saddle and horse from the horse from the knee to mid-calf. The knee should point forward and remain closed with no space between the exhibitor's knee and the saddle. The exhibitor will be penalized for positioning the legs excessively behind or forward of the vertical position. Regardless of the type of stirrup, the feet may be placed home in the stirrup, with the boot heel touching the stirrup, or may be placed with the ball of the foot in the center of the stirrup. The rider's toes should be pointing straight ahead or slightly turned out with the ankles straight or slightly broken in. Riding with toes only in the stirrup will be penalized. Those exhibitors that can maintain the proper position throughout all maneuvers should receive more credit. When riding without stirrups, the exhibitor should maintain the same position as previously described. Both hands and arms should be held in a relaxed, easy manner, with the upper arm in a straight line with the body. The arm holding the reins should be bent at the elbow forming a line from the elbow to the horse's mouth. The free hand and arm may be carried bent at the elbow in a similar position as the hand holding the reins or straight down at the rider's side. Excessive pumping of the free arm as well as excessive stiffness will be penalized. The rider's wrist is to be kept straight and relaxed, with the hand held at about 30 to 45 degrees inside the vertical. The rein hand should be carried immediately above or slightly in front of the saddle horn. The reins should be adjusted so that the rider has light contact with the horse's mouth, and at no time shall reins require more than a slight hand movement to control the horse. Excessively tight or loose reins will be penalized.

- c. The rider's head should be held with the chin level and the eyes forward, and may be directed slightly toward the direction of travel. Excessive turning of the head to the inside of the circle, or down at the horse's head or shoulder will be penalized.
- d. The exhibitor should not crowd the exhibitor next to or in front of them when working on the rail and should pass to the inside of the arena. When reversing on the rail, the exhibitor should always reverse to the inside of the arena.
- e. The horse's body condition and overall health and fitness should be assessed. The horse should appear fit and carry weight appropriate for the body size. A horse which appears sullen, dull, lethargic, emaciated, drawn, or overly tired should be penalized according to severity.
- f. Tack should fit the horse properly, and be neat, clean, and in good repair (see pages 13-15).

4. Performance of the Pattern

- a. The exhibitor should perform the work accurately, precisely, smoothly, and with a reasonable amount of promptness. Increasing speed of the maneuvers performed increases the degree of difficulty, however accuracy and precision should not be sacrificed for speed. Exhibitors that perform the pattern sluggishly and allow their horse to move without adequate impulsion, collection, or cadence will be penalized.
- b. The horse should perform all maneuvers in the pattern willingly, briskly, and readily with minimal visible or audible cueing. Faults, severe faults and reasons for disqualifications are provided below (Section 5).
- c. The horse should track straight, freely, and at the proper cadence for the prescribed gait. Transitions should be smooth and prompt in the pattern and on the rail, and should be performed when called for on the rail. The horse's head and neck should be straight and in line with their body while performing straight lines and slightly arched to the inside on curved lines or circles. Circles should be round, and performed at the appropriate speed, size, and location as requested in the pattern. The counter-canter should be performed smoothly with no change in cadence or stride unless specified in the pattern.

- d. The stop should be straight, square, prompt, smooth, and responsive with the horse maintaining a straight body position throughout the maneuver. The back should be smooth and responsive.
- 5. Turns should be smooth and continuous. When performing a turn on the haunches, the horse should pivot on the inside hind leg and step across with the front legs. A rollback is a stop and 180 degree turn over the hocks with no hesitation. Backing during turns will be penalized severely.
- e. The horse should step across the front and hind legs when performing the side pass, leg yield, and two-track. The side pass should be performed with the horse keeping the body straight while moving directly lateral in the specified direction. When performing a leg yield, the horse should move forward and lateral in a diagonal direction with the horse's body arced opposite to the direction that the horse is moving. In the two-track, the horse should move forward and lateral in a diagonal direction with the horse's body held straight or bent in the direction the horse is moving.
- f. A simple or flying change of lead should be executed precisely in the specified number of strides and/or at the designated location. A simple change of lead is performed by breaking to a walk or trot for one to three strides. Flying changes should be simultaneous front and rear. All changes should be smooth and timely.
- g. Position of the exhibitor and performance of the horse and rider on the rail must be considered in the final placing.

5. Scoring.

- a. Exhibitors are to be scored from 0 to infinity, with 70 denoting an average performance. Patterns will be divided into maneuvers and scored from +3 to -3 with increments of ½ pts acceptable.

SCORING SYSTEM: Exhibitors are to be scored from 0 to 100 with 70 denoting an average performance. One-half point increments are acceptable. Run content scores will be indicated as follows:

- +3= Excellent
- +2=Very Good
- +1=Good
- 0 = correct
- 1 = Poor
- 2 = Very Poor
- 3 = Extremely poor

Exhibitors overall horsemanship form and effectiveness should also be scored from 0 to 5 with 0-1 average, 2-3 good, 4 very good and 5 excellent.

- b. Penalties. Maneuver evaluations and penalty applications are to be determined independently. The following penalties will be applied for each occurrence and will be deducted from the final score:
- c. Three (3) points
 - Break of gait at walk or jog/trot up to 2 strides
 - Over/under turn from 1/8 to 1/4
 - Tick or hit of cone
- d. Five (5) points
 - Break of gait at a lope, out of lead or missing lead for 1-2 strides
 - Not performing the specific gait or not stopping when called for in the pattern within 10 feet of designated area
 - Incorrect gait or break of gait at walk or jog for more than 2 strides
 - Incorrect lead or break of gait (except when correcting an incorrect lead)
 - Obviously looking down to check leads
 - Loss of stirrup

- Head carried too low and/or clearly behind the vertical while the horse is in motion showing the appearance of intimidation
- e. Ten (10) points include:
- Loss of rein
 - Use of either hand to instill fear or praise
 - Holding saddle with either hand
 - Cueing with the end of the romal
 - Spurring in front of the cinch
 - Kicking at other horses, exhibitors or judge
 - Severe disobedience or resistance by horse including, but not limited to, rearing bucking or pawing
- f. *Off pattern (OP) Exhibitors going off pattern must always place below exhibitors not incurring a disqualifying fault. Judge shall include any appropriate penalties and OP in the penalty box for each occurrence. The judge shall place exhibitors with one (1) OP above an exhibitor with two (2) OP s regardless of the score*
- *Going off pattern*
 - *Knocking over or on wrong side of cone*
 - *Never performing specified gait*
 - *Overturning more than ¼ turn than designated*
- e. Disqualifications: (should not be placed)
- Failure by exhibitor to wear correct number in visible manner
 - Willful abuse, inhumane treatment
 - Excessive schooling or training
 - Fall by horse or rider
 - Illegal use of hands on reins
 - Use of prohibited equipment
 - Judge has the authority to excuse and/or disqualify any horse deemed unsafe or out of control
 - An exhibitor will be excused from the class (disqualified) if there is a tack or equipment breakage that the judge feels is a safety hazard

TRAIL

1. General Rules
 - a. Refer to Western Judged Division General Rules for acceptable tack, attire and equipment. Unless riding a five year old or younger in a snaffle or hackamore, only one hand may be used on reins and hands must not be changed. Except for horses shown with a hackamore or snaffle, only one hand may be used on the reins, except that it is permissible to change hands to work an obstacle. While horse is in motion, rider's hands shall be clear of horse and saddle.
 - b. This class will be judged on the performance of the horse over the obstacles with emphasis on manners, response to the rider, and quality of movement. Credit will be given to those horses negotiating the obstacles with style and some degree of speed, providing correctness is not sacrificed. Horses should receive credit for showing attentiveness to the obstacles and capability of picking their own way through the course when obstacles warrant it, and willingly responding to rider's cues on more difficult obstacles.
 - c. Horses may be allowed to cross enter Trail and Ranch Trail within the same horse show.

- d. Horse shall be penalized for any unnecessary delay while approaching or working an obstacle. Horses with artificial appearance over obstacles should be penalized.
- e. Horses must not be required to work on the rail. The course should be designed to require each horse to show the three gaits (walk, jog, lope) somewhere between obstacles as part of its work, and quality of movement and cadence should be considered as part of the maneuver score. Enough space must be provided for a horse to jog (at least 30 feet) and lope (at least 50 feet) for judges to evaluate these gaits. While on the line of travel between obstacles, the horse shall be balanced, carrying his head and neck in a relaxed, natural position, with the poll level with or slightly above the withers. The head should not be carried behind the vertical, giving the appearance of intimidation, or be excessively nosed out, giving a resistant appearance.
- f. At least six obstacles will be used; at least three of which will be mandatory and three others selected from the approved list. The gait between obstacles shall be at the discretion of the judge. No flying lead changes are allowed.
- g. The course to be used must be posted or distributed to exhibitors at least one hour before scheduled time of the class.
- h. All courses and obstacles are to be constructed with safety in mind so as to eliminate any accidents. Courses for younger age group (Juniors) should be less difficult than courses for older youth. When the distances and spaces are measured between all obstacles, the inside base to inside base measurement of each obstacle considering the normal path of the horse, should be the measuring point.
- i. If disrupted, the course shall be reset after each horse has worked. In the case that a combination of obstacles is used, the course cannot be reset until the contestant finishes the entire course regardless of where any disruption occurs.
- j. If undue delay occurs after the horse enters or begins working an obstacle or safety of rider is of concern, the judge may motion rider to next obstacle (Rider to receive all incurred penalties, allowed to work other obstacles, and will receive score for pattern).

2. Mandatory obstacles are:

- a. Opening, passing through and closing gate. (Losing control of gate is to be penalized.) Use a gate that will not endanger horse or rider. If the gate has a metal, plastic or wooden support bar under the opening, contestants must work the gate moving forward through it. Gate work can be specified as to which hand and side of horse is on the gate, and if gate is to be pulled toward the horse upon opening or the gate is pushed so that the gate is worked as the rider moves through the gate opening. A left hand pull instruction would mean the rider's left hand is on the gate, the right hand on the reins, and the horse is positioned so the gate is on the left side of the horse, and the rider is to pull the gate toward the direction of the horse to open it.
- b. Ride over at least four logs or poles. These can be in a straight line, curved, zigzag or raised. The space between the logs is to be measured and the path the horse is to take should be the measuring point. The space for walk-overs shall be 20-24 inches; trot-overs 3' to 3'6", and lope-overs 6' to 7'. Walkovers may be elevated to 12 inches and should be a minimum of 22 inches apart. Trot-overs and lope-overs can be elevated a maximum of 8 inches. All elevated obstacles must be placed in a cup, notched block or otherwise secured so they cannot roll. Measure the height from the ground to the top of the element.
- c. Backing obstacle. The backing obstacle is to be spaced a minimum of 28 inches; if elevated, 30 inches minimum space. Entrants cannot be asked to back over a stationary object such as a wooden pole or metal bar.
 - i. Back through and around at least three markers.

ii. Back through L, V, U, straight or similar shaped course. May be elevated no more than 24 inches.

3. Optional obstacles, but not limited to:

- a. Ride over wooden bridge. (Suggested minimum width shall be 36 inches wide and at least six feet long.) Bridge should be safe, sturdy and negotiated at a walk.
- b. Simulated water hazard (ditch or small pond with no water). No metal or slick bottom boxes will be used.
- c. Serpentine obstacles at walk or jog or trot. Spacing is to be a minimum of 6 feet for the jog or trot.
- d. Carry object from part of arena to another. (Only objects which reasonably might be carried on a trail ride may used.)
- e. Put on and remove slicker.
- f. Remove and replace materials from mailbox.
- g. Side pass (may be elevated to 12 inches maximum).
- h. An obstacle consisting of four logs or rails, each 5 to 7 feet long, laid in a square. Each contestant will enter the square by riding over log or rail as designated. When all four feet are inside the square, rider should execute a turn as indicated and depart.
- i. Use of any other safe and negotiable obstacle that could reasonably be expected to be encountered on a trail ride, providing the obstacle meets the judge's approval.
- j. A combination of two or more of any obstacle is acceptable. Obstacles that should not be used include tires, animals, hides, PVC pipe, elevated obstacles above the height of maximum allowable heights for walk, trot or lope overs (jumps), rocking or moving bridges, water box with floating or moving parts, flames, dry ice, fire extinguisher, etc. logs or poles elevated in a manner that permits such to roll, dismounting or ground ties.
- k. The judge has the right and duty to alter the course in any manner or remove any obstacle he deems unsafe or non-negotiable. If at any time a trail obstacle is deemed to be unsafe by the judge, it shall be repaired or removed from the course. If it cannot be repaired and horses have completed the course, the score for that obstacle shall be deducted from all previous works for that class.

4. Scoring

1. Scoring will be on the basis of zero to infinity, with 70 denoting an average performance. Each obstacle will receive an obstacle score that should be added or subtracted from 70. Each obstacle will be scored on the following basis, ranging from plus 1 1/2 to minus 1 1/2; -1 1/2 extremely poor, -1 very poor, -1/2 poor, 0 correct, +1/2 good, +1 very good, +1 1/2 excellent. Obstacle scores are to be determined and assessed independently of penalty points.
2. Faults, which occur on the line of travel between obstacles, scored according to severity:

Head carried too low (tip of ear below the withers consistently), over-flexing or straining neck in head carriage so the nose is carried behind the vertical consistently, excessive nosing out, and opening mouth excessively between obstacles. Repeated or excessively touching the horse on the neck to lower the head between or during obstacles.

3. The following penalty deductions should be assessed per occurrence as follows:

One half 1/2 Point

- Each tick (light touch) of log, pole, cone, plant, or any component of the obstacle.

One 1 Point

- Each bite of or hit of or stepping on a log, pole, cone or any component of the obstacle.
- Incorrect or break of gait at walk or jog for two strides or less.
- Both front or both hind feet in a single-strided slot or space at a walk or jog.
- Skipping over or failing to step into a required space.
- Split pole in lope-over.
- Incorrect number of strides, if specified

Three 3 Point

- Incorrect or break of gait at walk or jog for more than 2 strides.
- Out of lead or break of gait at lope (except when correcting an incorrect lead).
- Knocking down an elevated pole, cone, barrel, plant obstacle, or severely disturbing an obstacle.
- Stepping outside the confines of or stepping off or out of an obstacle with designated boundaries with one foot that has entered an obstacle, including missing one element of an obstacle on a line of travel with one foot.
- Falling or jumping off or out of a bridge or a water box with one foot once the horse has got onto or into that obstacle

Five 5 Point

- Letting go of gate, or dropping rope gate.
- Dropping slicker or object required to be carried on course.
- First or second cumulative refusal, balk, or attempting to evade an obstacle by shying or backing more than 2 strides away.
- Holding saddle with either hand.
- Blatant disobedience (including kicking out, bucking, rearing, striking, balking, freezing up).
- Stepping outside the confines of, falling or jumping off or out of an obstacle with designated boundaries (ie. back through, 30 degree box, side pass) with more than one foot once the foot has entered the obstacle; includes missing one element of an obstacle on a line of travel with more than one foot
- Use of either hand to instill fear or praise.

Off Pattern (OP): While avoiding disqualification; entries should be placed below those that complete the pattern correctly. Judge shall include any appropriate penalties OP in the penalty box for each occurrence. The judge shall place exhibitors with one (1) OP above an exhibitor with two (2) OP s regardless of the score

- *For a particular obstacle, the third cumulative refusal, balk, or evading an obstacle by shying or backing, (This penalty is in addition to the two -5 penalties received for the first and second cumulative refusal.) Judge is allowed to motion rider on after third refusal on an obstacle. Judge's decision to motion a rider on is at judge's discretion and not subject to protest.*
- *Entering or exiting obstacle from the incorrect side or direction.*
- *Working an obstacle in an incorrect direction including under or overturns of more than 1/4.*
- *Failure to follow correct line of travel between obstacles.*
- *Failure to ever demonstrate designated gait between/within an obstacle*

- *Use of more than one finger between reins(index finger only between reins), use of two hands with exceptions listed in western equipment section with snaffles and hackamores, changing of hands on reins unless changing hands to work an obstacle, incorrect use of romal (see western equipment section)*

Disqualification for Course (Non-placing score):

- No attempt to perform an obstacle.
- Performing the obstacles other than in specified order.
- Riding outside designated boundary marker of the course, such as leaving the arena or area that the trail pattern is set up.
- Equipment failure that delays completion of pattern.
- Fall of horse or rider.
- Excessive schooling, pulling, turning, stepping or backing anywhere on course
- Judge has the authority to excuse and/or disqualify any horse deemed unsafe or out of control. An exhibitor will be excused from the class (disqualified) if there is a tack or equipment breakage that the judge feels is a safety hazard.

REINING

1. General Rules

- Refer to Western Division General Rules for acceptable tack, attire and equipment. Unless riding a five year old or younger in a snaffle or hackamore, only one hand may be used on reins and hands must not be changed.
- Each contestant will perform the required pattern individually and separately.
- To rein a horse is not only to guide him but also to control his every movement. The best-reined horse should be willingly guided or controlled with little or no apparent resistance and dictated to completely. Any movement on his own must be considered a lack of control. All deviations from the exact written pattern must be considered a lack of/or temporary loss of control and therefore a fault that must be marked down according to severity of deviation. Credit will be given for smoothness, finesse, attitude, quickness and authority of performing the various maneuvers while using controlled speed.

2. Scoring

- The scoring will be on a basis of zero to infinity, with 70 denoting an average performance. The individual maneuvers are scored in ½ point increments from a low of -1 ½ to a high of +1 1/2. Points will be added or subtracted from the maneuvers on the following basis, -1 1/2 extremely poor, -1 very poor, -1/2 poor, 0 average, +1/2 good, +1 very good, +1 1/2 excellent. Maneuver scores are to be determined independently of penalty points.
- Any ties for first should be worked off (unless the tied exhibitors unanimously agree to flip of coin instead), using the same pattern and order of go as was used during the event; however, there will not be more than one run off. If a tie occurs after the run-off, the entrants will be named co-champions; and must determine the winner of the awards by a flip of a coin.
- All horses will be judged immediately upon entering the arena and judging will cease after the last maneuver. Any fault incurred prior to the commencement of a pattern will be scored accordingly.
- The following will result in no score (not placed, disqualified, **cannot advance to state**):

- Abuse of an animal in the show arena and/or evidence that an act of abuse has occurred prior to or during the exhibition of a horse in competition.
 - Use of illegal equipment, including wire on bits, bosals or curb chains.
 - Use of illegal bits, bosals or curb chains.
 - Closed reins are not allowed except as standard romal reins.
 - Use of tack collars, tie-downs or nosebands.
 - Use of whips or bats.
 - Use of any attachment that alters the movement of or circulation to the tail.
 - Failure to provide horse and equipment to the appropriate judge for inspection.
 - Disrespect or misconduct by the exhibitor.
- e. "Penalty score 0" (*not placed, but can advance to state*):
- Use of more than index or first finger between reins.
 - Use of two hands (exception in snaffle bit or hackamore classes designated for two hands) or changing hands.
 - Use of romal other than as explained in general western equipment rules.
 - Failure to complete pattern as written.
 - Performing the maneuvers other than in specified order.
 - The inclusion of maneuvers not specified, including, but not limited to:
 - Backing more than 2 strides.
 - Turning more than 90 degrees.
 - On run in patterns, once beginning a canter a complete stop prior to reaching the first marker. (Exception: a complete stop in the 1st quarter of a circle after a canter departure is not to be considered an inclusion of maneuver; rather a two point break of gait penalty will apply.
 - Equipment failure that delays completion of pattern.
 - Balking or refusal of command where performance is delayed.
 - Running away or failing to guide where it becomes impossible to discern whether the entry is on pattern.
 - Jogging in excess of one-half circle or one-half the length of the arena.
 - Over spins of more than 1/4 turn.
 - Fall to the ground by horse or rider.
 - When going to and coming out of a rollback in a pattern requiring a run-around, a rollback that crosses the center line
 - Exceeds greater than one quarter of the circle out of order
 - Dropping a rein that contacts the ground while the horse is in motion

NOTE: A 0 score may be allowed to enter the state show.

- f. Excess rein may be straightened at any place a horse is allowed to be completely stopped during a pattern, provided the rider's free hand remains behind the rein hand. Any attempt to alter tension or length of the reins from bridle to the rein hand is to be considered use of two hands a penalty score of zero will be applied. In addition, should the judge determine the free hand is being used to instill fear or praise, a penalty five will be applied, and a reduction in the maneuver score. When using a romal, the romal reins can only pass through the hand once, the rider's hand shall be around the reins with the wrist kept straight and relaxed, the thumb on top and the hand closed around the reins; no fingers between the reins are allowed. The free hand may be used to hold the romal provided it is held in a relaxed position and there is at least 16" of romal from the free hand to the reining hand. Rider's free hand may be used to hold romal in the normal fashion. A rider must be allowed to untangle or straighten the horse's mane at any place a horse is allowed to be complete.

- g. Five 5 points:
- a. Spurring in front of cinch.
 - b. Use of free hand to instill fear.
 - c. Blatant disobedience including but not limited to kicking, biting, bucking, rearing and striking.
 - d. Holding on to the saddle with either hand.
 - e. the act of a horse dropping to its knees or hocks
- h. Two 2 point penalty:
- a. Break of gait.
 - b. Freezing up in spins or rollbacks.
 - c. On walk in patterns, loping prior to reaching the center of the arena and/or failure to stop or walk before executing a lope departure.
 - d. On run in patterns, failure to be in a lope prior to reaching the first marker or break of gait prior to the first marker.
 - e. If a horse does not completely pass the specified marker before initiating a stop position.
- i. Starting or performing circles or eights out of lead will be judged as follows: Each time a horse is out of lead, a judge is required to penalize by 1 point. The penalty for being out of lead is accumulative, and the judge will add 1 penalty point for each 1/4 of the circumference of a circle or any part thereof that a horse is out of lead. A judge is required to penalize a horse 1/2 of a point for a delayed change of lead by one stride where the lead change is required by the pattern description.
- j. Deduct 1/2 point for starting circle at a jog or exiting rollbacks at a jog up to 2 strides. Jogging beyond 2 strides, but less than 1/2 circle or 1/2 the length of the arena, deduct 2 points.
- k. Deduct 1/2 point for over or under spinning up to 1/8 of a turn; deduct 1 point for over or under spinning up from 1/8 to 1/4 of a turn.
- l. There will be a 1/2 point penalty for failure to remain a minimum of 20 feet from wall or fence when approaching a stop and/or rollback.
- m. In patterns requiring a run-around, failure to be on the correct lead when rounding the end of the arena will be penalized as follows: for 1/2 the turn or less, one point, for more than 1/2 turn, two points.
- n. In patterns requiring a run-around, there will be a one half (1/2) point penalty for failure to remain a minimum of 10 feet from either side of the center of the arena

NRHA 1

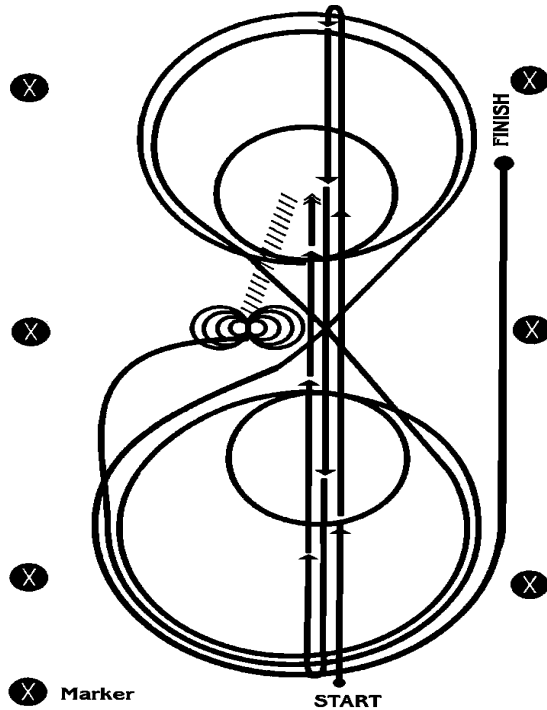

1. Run at speed to the far end of the arena past the end marker and do a left rollback - no hesitation.
2. Run to the opposite end of the arena past the end marker and do a right rollback - no hesitation.
3. Run past the center marker and do a sliding stop. Back up to center of the arena or at least ten feet (3 meters). Hesitate.
4. Complete four spins to the right. Hesitate.
5. Complete four and one-quarter spins to the left so that horse is facing left wall or fence. Hesitate.
6. Beginning on the left lead, complete three circles to the left: the first circle large and fast; the second circle small and slow; the third circle large and fast. Change leads at the center of the arena.
7. Complete three circles to the right: the first circle large and fast; the second circle small and slow; the third circle large and fast. Change leads at the center of the arena.
8. Begin a large fast circle to the left, but do not close this circle. Run straight up the right side of the arena past the center marker and do a sliding stop at least twenty feet (6 meters) from the wall or fence. Hesitate to demonstrate the completion of the pattern.

Rider may drop bridle to the designated judge.

The patterns are to be worked as stated, not as drawn. The drawn pattern is just to give the general idea of what the pattern will look like in the arena.

NRHA 2

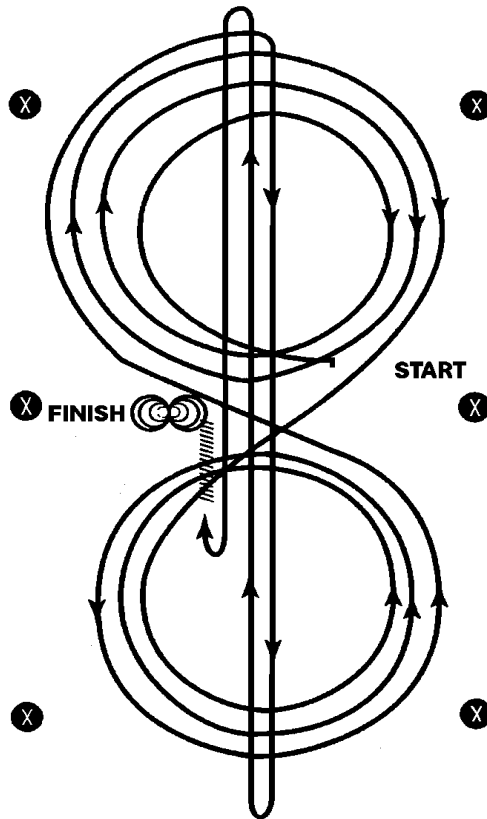

Horses may walk or trot to the center of arena. Horse must walk or stop prior to starting pattern beginning at the center of the arena facing the left wall or fence.

1. Beginning on the right lead, complete three circles to the right: the first circle small and slow; the next two circles large and fast. Change leads at the center of the arena.
2. Complete three circles to the left: the first circle small and slow; the next two circles large and fast. Change leads at the center of the arena.
3. Continue around previous circle to the right. At the top of the circle, run down the middle to the far end of the arena past the end marker and do a right rollback - no hesitation.
4. Run up the middle to the opposite end of the arena past the end marker and do a left rollback - no hesitation.
5. Run past the center marker and do a sliding stop. Back up to the center of the arena or at least ten feet (3 meters). Hesitate.
6. Complete four spins to the right. Hesitate.
7. Complete four spins to the left. Hesitate to demonstrate the completion of the pattern.

Rider may drop bridle to the designated judge.

The patterns are to be worked as stated, not as drawn. The drawn pattern is just to give the general idea of what the pattern will look like in the arena.

NRHA 3

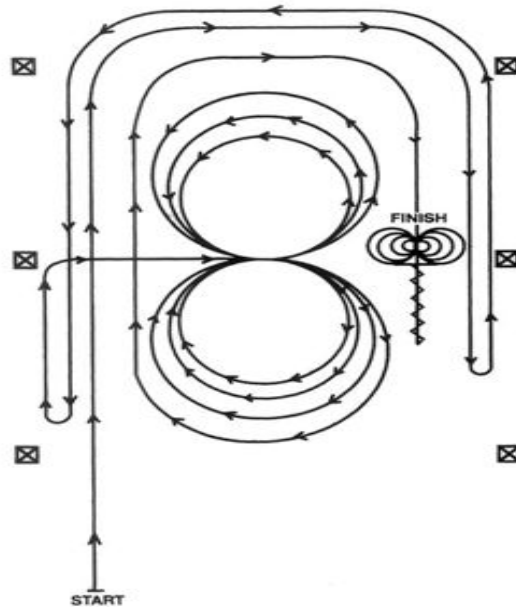

1. Beginning, lope straight up the left side of the arena, circle the top end of the arena, and staying at least 20 feet from walls or fence, run straight down the opposite or right side of the arena past the center marker and do a left rollback – no hesitation.
2. Continue straight up the right side of the arena circle back around the top of the arena, and staying at least 20 feet from the wall or fence, run straight down the left side of the arena past the center marker and do a right rollback – no hesitation.
3. Continue up the left side of the arena to the center marker. At the center marker, the horse should be on the right lead. Guide the horse to the center of the arena on the right lead and complete three circles to the right; the first two circles large and fast; the third circle small and slow. Change leads at the center of the arena.
4. Complete three circles to the left: the first two circles large and fast; the third circle small and slow. Change leads in the center of the arena.
5. Begin a large fast circle to the right but do not close this circle. Continue up the left side of the arena, circle the top of the arena, and staying at least 20 feet from the wall or fence, run straight down the opposite or right side of the arena past the center marker and do a sliding stop. Back up at least 10 feet. Hesitate.
6. Complete four spins to the right. Hesitate.
7. Complete four spins to the left. Hesitate to demonstrate completion of the pattern.

Rider may drop bridle to the designated judge.

The patterns are to be worked as stated, not as drawn. The drawn pattern is just to give the general idea of what the pattern will look like in the arena.

NRHA 4

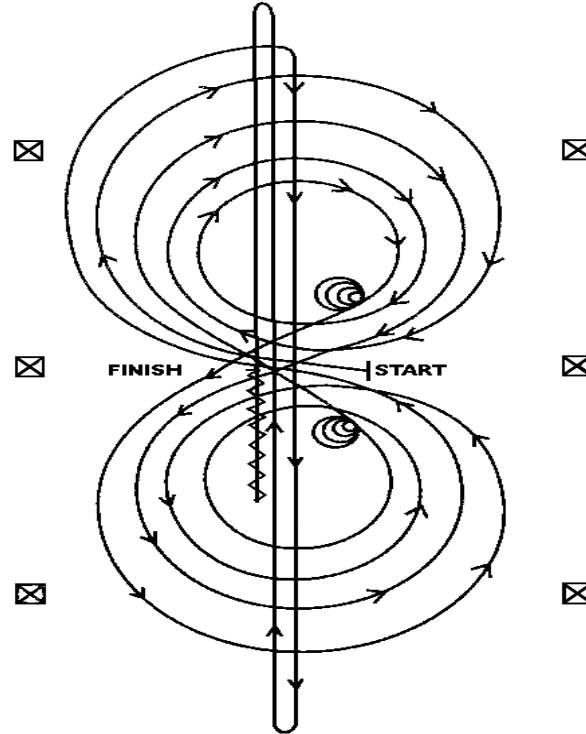

Horses may walk or trot to the center of arena. Horses must walk or stop prior to starting pattern beginning at the center of the arena facing the left wall or fence.

1. Beginning on the right lead, complete three circles to the right: the first two circles large and fast; and the third circle small and slow. Stop at the center of the arena.
2. Complete four spins to the right. Hesitate.
3. Beginning on the left lead, complete three circles to the left: the first two circles large and fast; the third circle small and slow. Stop at the center of the arena. Hesitate.
4. Complete four spins to the left. Hesitate.
5. Beginning on the right lead, run a large fast circle to the right, change leads at the center of the arena, run a large fast circle to the left, and change leads at the center of the arena. (Figure 8).
6. Continue around previous circle to the right. At the top of the circle, run down the middle to the far end of the arena past the end marker and do a right rollback - no hesitation.
7. Run up the middle to the opposite end of the arena past the end marker and do a left rollback - no hesitation.
8. Run past the center marker and do a sliding stop. Back up to the center of the arena or at least ten feet (3 meters). Hesitate to demonstrate completion of the pattern.

Rider may drop bridle to the designated judge.

The patterns are to be worked as stated, not as drawn. The drawn pattern is just to give the general idea of what the pattern will look like in the arena.

NRHA 5

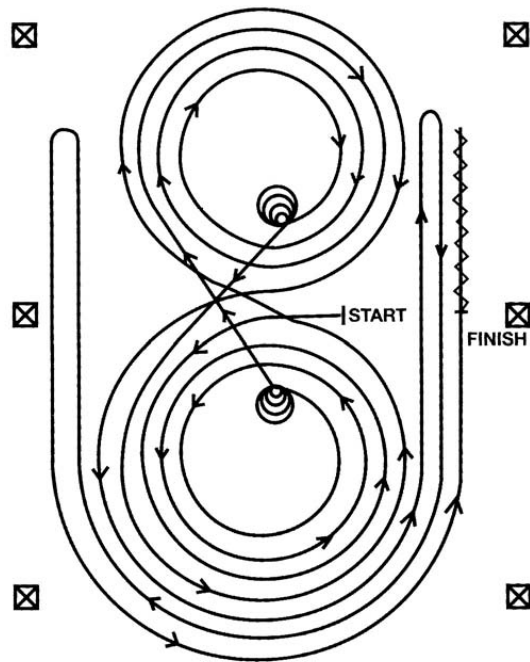

Horses may walk or trot to the center of arena. Horses must walk or stop prior to starting pattern. Beginning at the center of the arena facing the left wall or fence.

1. Beginning on the left lead, complete three circles to the left: the first two circles large and fast; the third circle small and slow. Stop at the center of the arena. Hesitate.
2. Complete four spins to the left. Hesitate.
3. Beginning on the right lead, complete three circles to the right: the first two circles large and fast; the third circle small and slow. Stop at the center of the arena. Hesitate.
4. Complete four spins to the right. Hesitate.
5. Beginning on the left lead, run a large fast circle to the left, change leads at the center of the arena, run a large fast circle to the right, and change leads at the center of the arena. (Figure 8)
6. Continue around previous circle to the left but do not close this circle. Run up the right side of the arena past the center marker and do a right rollback at least twenty feet (six meters) from the wall or fence – no hesitation.
7. Continue around previous circle but do not close this circle. Run up the left side of the arena past the center marker and do a left rollback at least twenty feet (six meters) from the wall or fence – no hesitation.
8. Continue back around previous circle but do not close this circle. Run up the right side of the arena past the center marker and do a sliding stop at least twenty feet (six meters) from the wall or fence. Back up at least ten feet (three meters). Hesitate to demonstrate completion of the pattern.

Rider may dismount and drop bridle to the designated judge.

The patterns are to be worked as stated, not as drawn. The drawn pattern is just to give the general idea of what the pattern will look like in the arena.

NRHA 6

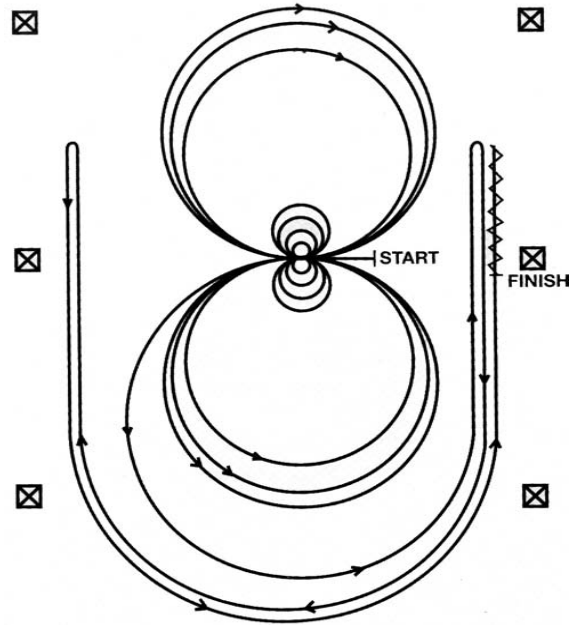

Horses may walk or trot to the center of arena. Horses must walk or stop prior to starting pattern. Beginning at the center of the arena facing the left wall or fence.

1. Complete four spins to the right. Hesitate.
2. Complete four spins to the left. Hesitate.
3. Beginning on the left lead, complete three circles to the left: the first two circles large and fast; the third circle small and slow. Change leads at the center of the arena.
4. Complete three circles to the right: the first two circles large and fast; the third circle small and slow. Change leads at the center of the arena.
5. Begin a large fast circle to the left but do not close this circle. Run up the right side of the arena past the center marker and do a right rollback at least twenty feet (six meters) from the wall or fence – no hesitation.
6. Continue back around previous circle but do not close this circle. Run up the left side of the arena past the center marker and do a left rollback at least twenty feet (six meters) from the wall or fence – no hesitation.
7. Continue back around previous circle but do not close this circle. Run up the right side of the arena past the center marker and do a sliding stop at least twenty feet (six meters) from the wall or fence. Back up at least ten feet (three meters). Hesitate to demonstrate the completion of the pattern.

Rider may dismount and drop bridle to the designated judge.

The patterns are to be worked as stated, not as drawn. The drawn pattern is just to give the general idea of what the pattern will look like in the arena.

NRHA 7

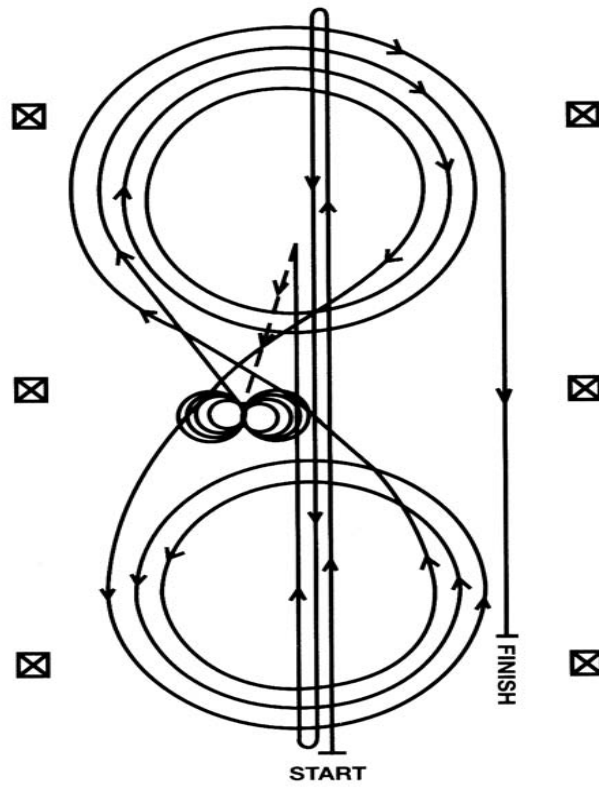

1. Run at speed to the far end of the arena past the end marker and do a left rollback-no hesitation.
2. Run to the opposite end of the arena past the end marker and do a right rollback-no hesitation.
3. Run past the center marker and do a sliding stop. Back up to the center of the arena or at least ten feet (three meters). Hesitate.
4. Complete four spins to the right. Hesitate.
5. Complete four and one-quarter spins to the left so that horse is facing left wall or fence. Hesitate.
6. Beginning on the right lead, complete three circles to the right: the first two circles large fast; the third circle small and slow. Change leads at center of the arena.
7. Complete three circles to the left: the first two circles large fast; the third circle small and slow. Change leads at the center of the arena.
8. Begin a large fast circle to the right but do not close this circle. Run straight down the right side of the arena past the center marker and do a sliding stop at least twenty feet (six meters) from the wall or fence. Hesitate to demonstrate completion of the pattern.

Rider may drop bridle to the designated judge.

The patterns are to be worked as stated, not as drawn. The drawn pattern is just to give the general idea of what the pattern will look like in the arena.

NRHA 8

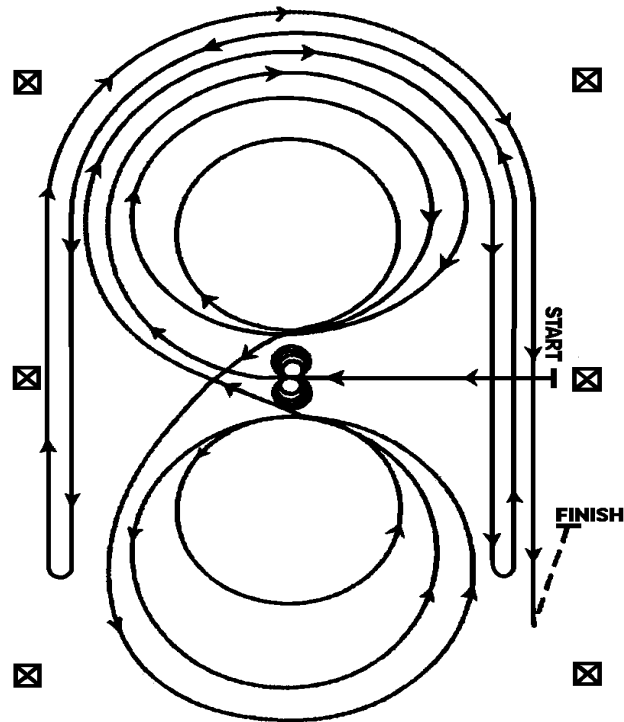

Horses may walk or trot to the center of arena. Horses must walk or stop prior to starting pattern beginning at the center of the arena facing the left wall or fence.

1. Complete four spins to the left. Hesitate.
2. Complete four spins to the right. Hesitate.
3. Beginning on the right lead, complete three circles to the right: the first circle large and fast; the second circle small and slow; the third circle large and fast. Change leads at the center of the arena.
4. Complete three circles to the left: the first circle large and fast; the second circle small and slow; the third circle large and fast. Change leads at the center of the arena.
5. Begin a large fast circle to the right, but do not close this circle. Run down the right side of the arena past the center marker and do a left rollback at least twenty feet from the wall or fence - no hesitation.
6. Continue back around the previous circle, but do not close this circle. Run straight down the left side of the arena past the center marker and do a right rollback at least twenty feet from the wall or fence - no hesitation.
7. Continue back around the previous circle, but do not close this circle. Run down the right side of the arena past the center marker and do a sliding stop at least twenty feet (6 meters) from the wall or fence. Back up at least ten feet. Hesitate to demonstrate completion of the pattern.

Rider may drop bridle to the designated judge.

The patterns are to be worked as stated, not as drawn. The drawn pattern is just to give the general idea of what the pattern will look like in the arena.

NRHA 9

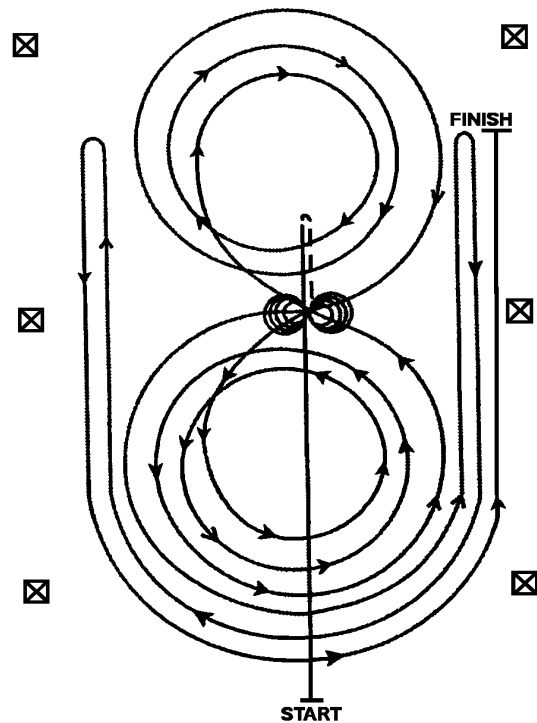

1. Run past the center marker and do a sliding stop. Back up to the center of the arena or at least ten feet (3 meters). Hesitate.
2. Complete four spins to the right. Hesitate.
3. Complete four and one-quarter spins to the left so that the horse is facing the left wall or fence. Hesitate.
4. Beginning on the left lead, complete three circles to the left: the first circle small and slow; the next two circles large and fast. Change leads at the center of the arena.
5. Complete three circles to the right: the first circle small and slow, the next two circles large and fast. Change leads at the center of the arena.
6. Begin a large fast circle to the left but do not close this circle. Run up the right side of the arena past the center marker and do a right rollback at least twenty feet (6 meters) from the wall or fence - no hesitation.
7. Continue back around the previous circle but do not close this circle. Run up the left side of the arena past the center marker and do a left rollback at least twenty feet (6 meters) from the wall or fence - no hesitation.
8. Continue back around previous circle but do not close this circle. Run up the right side of the arena past the center marker and do a sliding stop at least twenty feet (6 meters) from the wall or fence. Hesitate to demonstrate completion of pattern.

Rider may drop the bridle to the designated judge.

The patterns are to be worked as stated, not as drawn. The drawn pattern is just to give the general idea of what the pattern will look like in the arena.

NRHA 10

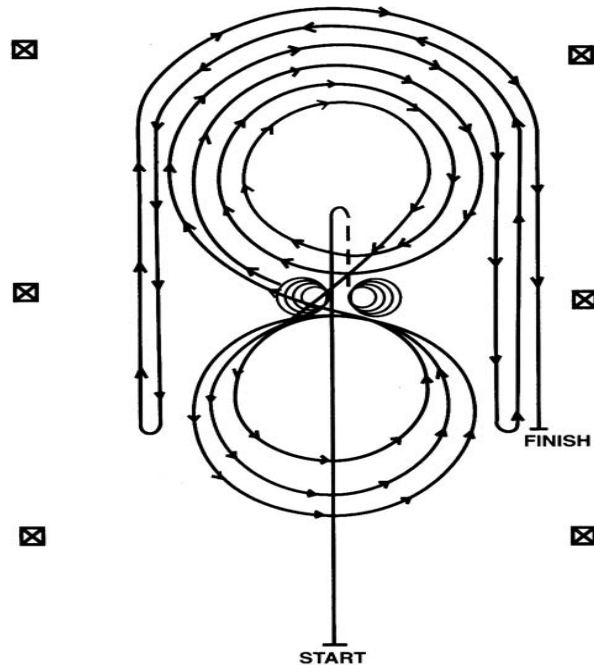

1. Run past the center marker and do a sliding stop. Back up to the center of the arena or at least ten feet (3 meters). Hesitate.
2. Complete four spins to the right. Hesitate.
3. Complete four and one-quarter spins to the left so that the horse is facing the left wall or fence. Hesitate.
4. Beginning on the right lead, complete three circles to the right: the two circles large and fast, the third circle small and slow. Change leads at the center of the arena.
5. Complete three circles to the left: the first circle small and slow, the next two circles large and fast. Change leads at the center of the arena.
6. Begin a large fast circle to the right but do not close this circle. Run up the right side of the arena past the center marker and do a left rollback at least twenty feet (6 meters) from the wall or fence - no hesitation.
7. Continue back around the previous circle but do not close this circle. Run down the left side of the arena past the center marker and do a right rollback at least twenty feet (6 meters) from the wall or fence - no hesitation.
8. Continue back around previous circle but do not close this circle. Run down the right side of the arena past the center marker and do a sliding stop at least twenty feet (6 meters) from the wall or fence. Hesitate to demonstrate completion of pattern.

Rider may drop the bridle to the designated judge.

The patterns are to be worked as stated, not as drawn. The drawn pattern is just to give the general idea of what the pattern will look like in the arena.

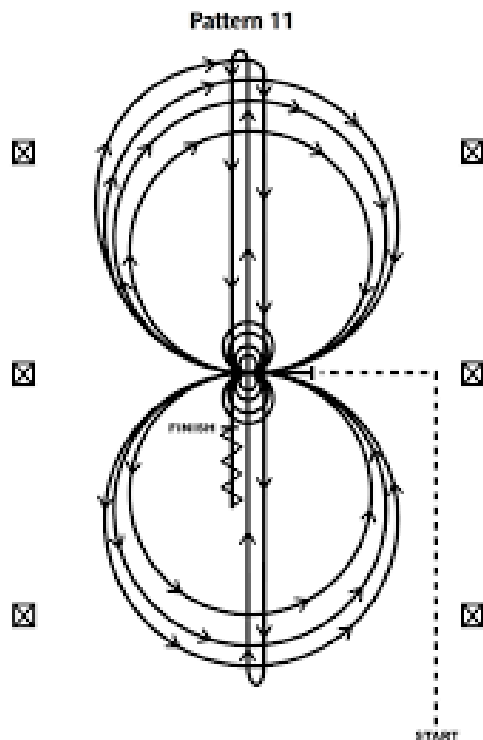

Horses must jog the majority of the way to the center. Failure to jog the majority of the way to the center will result in a 0 for failure to complete the pattern as written. Horses must walk or stop prior to starting pattern. Beginning at the center of the arena facing the left wall or fence.

1. Complete four spins to the left. Hesitate.
 2. Complete four spins to the right. Hesitate.
 3. Beginning on the right lead, complete three circles to the right; the first circle small and slow; the next two circles large and fast. Change leads at the center of the arena.
 4. Complete three circles to the left; the first circle small and slow; the next two circles large and fast. Change leads at the center of the arena.
 5. Begin a large circle to the right, but do not close this circle.
- Run down the center of the arena past the end marker and do a right rollback - no hesitation.
6. Run up the middle to the opposite end of the arena past the end marker and do a left rollback - no hesitation.
 7. Run past the center marker and do a sliding stop. Back up to the center of the arena or at least 10 feet (3 meters).
- Hesitate to demonstrate completion of the pattern.

NRHA 12

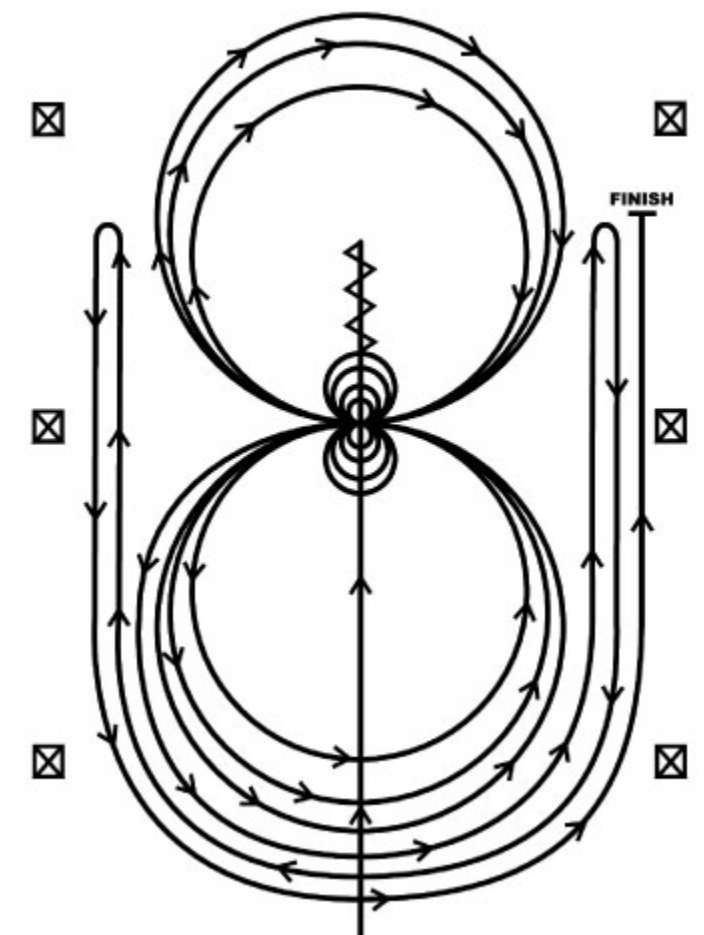

1. Run past the center marker and do a sliding stop. Back up to the center of the arena or at least 10 feet (3 meters). Hesitate.
2. Complete four spins to the right.
3. Complete four and one-quarter spins to the left so that the horse is facing the left wall or fence. Hesitate.
4. Beginning on the left lead, complete three circles to the left: the first two circles large and fast; the third circle small and slow. Change leads at the center of the arena.
5. Complete three circles to the right: the first two circles large and fast; the third circle small and slow
6. Begin a large fast circle to the left but do not close the circle. Run up the right side of the arena past the center marker and do a right rollback at least 20 feet (6 meters) from the wall or fence-no hesitation.
7. Continue back around previous circle but do not close the circle. Run up the left side of the arena and past the center marker and do a left rollback at least 20 feet (6 meters) from the wall or fence-no hesitation.
8. Continue back around previous circle but do not close this circle. Run up the right side of the arena past the center marker and do a sliding stop at least 20 feet (6 meters) from the wall or fence.

Rider may drop bridle to the designated judge

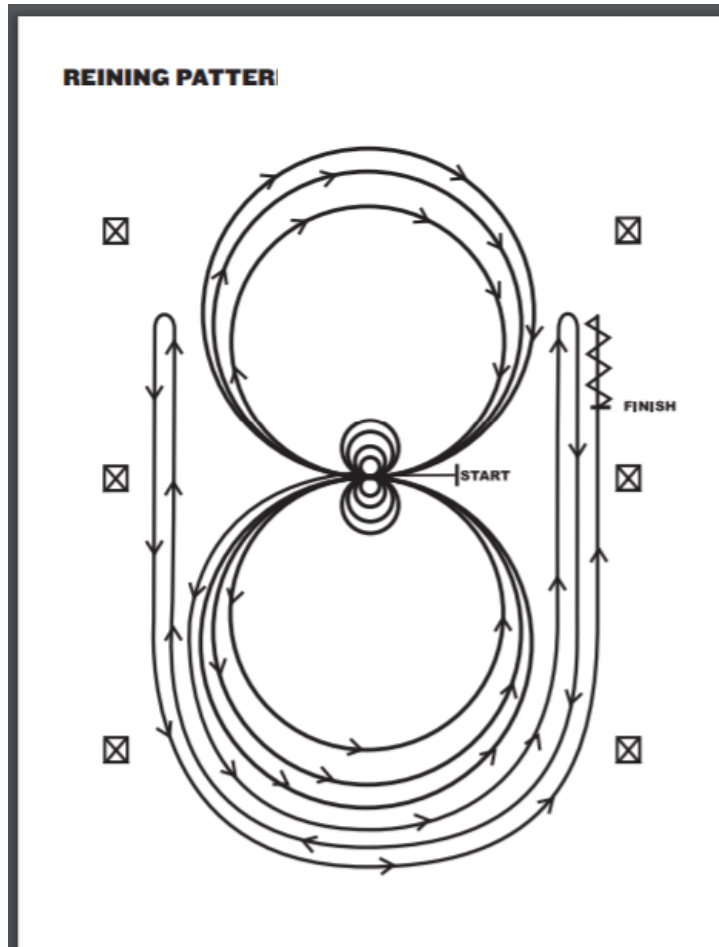

Horses must walk or stop prior to starting pattern.

Beginning at the center of the arena facing the left wall or fence.

1. Beginning on the left lead, complete two circles to the left: the first circle large and fast; the second circle small and slow. Stop at the center of the arena.
2. Complete four spins to the left. Hesitate
3. Beginning on the right lead, complete two circles to the right: the first being large and fast; the second circle small and slow. Stop at the center of the arena.
4. Complete four spins to the right. Hesitate
5. Beginning on the left lead, run a large fast circle to the left, change leads at the center of the arena, run a large fast circle to the right, and change leads at the center of the arena.
6. Continue around previous circle to the left but do not close this circle. Run up the right side of the arena past the center marker and do a right rollback at least 20 feet (6 meters) from the wall or fence-no hesitation
7. Continue around previous circle but do not close this circle. Run up the left side of the arena past the center marker and do a left rollback at least 20 feet (6 meters) from the wall or fence-no hesitation.
8. Continue back around previous circle but do not close this circle. Run up the right side of the arena past the center marker and do a sliding stop at least 20 feet (6 meters) from the wall or fence. Back up at least 10 feet (3 meters).

Hesitate to demonstrate completion of the pattern.

Rider may drop bridle to the designated judge

NRHA Pattern A

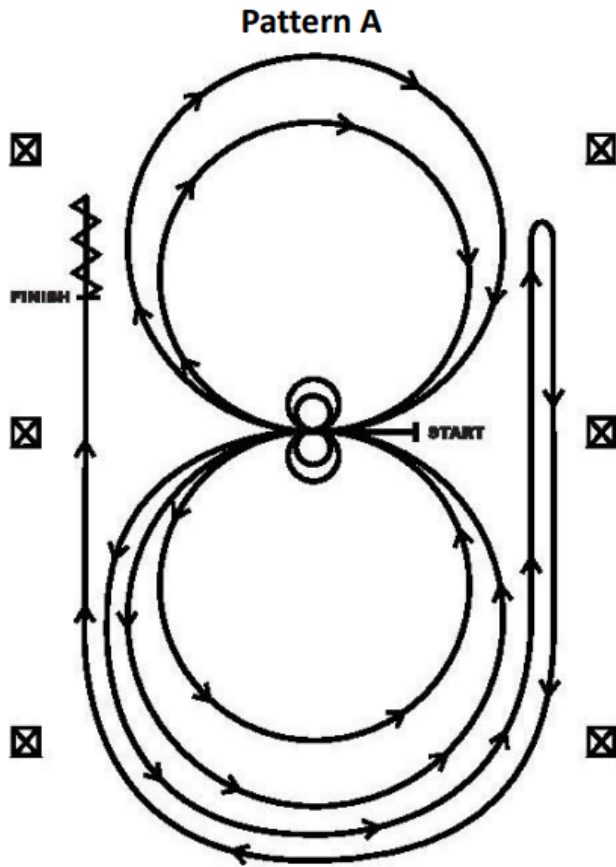

Horses may walk or jog to the center of the arena. (To assist with the show schedule, show management may require that horses be jogged to center. Show management is responsible for posting this requirement.) Horses must walk or stop prior to starting the pattern. Beginning at the center of the arena facing the left wall or fence.

1. Beginning on the left lead, complete two circles to the left. Stop at the center of the arena. Hesitate.

2. Complete two spins to the left. Hesitate.

3. Beginning on the right lead complete two circles to the right. Stop at the center of the arena. Hesitate.

4. Complete two spins to the right. Hesitate.

5. Beginning on the left lead, go around the end of the arena, run down the right side of the arena past center marker, stop and roll back right.

6. Continue around the end of the arena to run down the left side of the arena past the center marker. Stop. Back up. Hesitate to demonstrate completion of the pattern.

NRHA Pattern B

1. Beginning, lope straight up the right side of the arena, circle the top of the arena run straight down the opposite or left side of the arena past the center mark and do a right rollback—no hesitation.
2. Continue straight up the left side of the arena circle back around the top of the arena run straight down the right side of the arena past the center marker and do a left rollback—no hesitation.
3. Continue up the right side of the arena to the center marker, at the center marker the horse should be on the left lead and complete two circles to the left, one large fast and one small slow. Stop at center. Hesitate.
4. Complete three spins to the left. Hesitate.
5. Complete two circles to the right, one large fast and one small slow. Stop at center. Hesitate.
6. Complete three spins to the right. Hesitate.
7. Begin a large circle to the left, do not close the circle. Continue up the center of the arena past the center marker and do a sliding stop. Back up at least ten feet. Hesitate to demonstrate completion of the pattern.

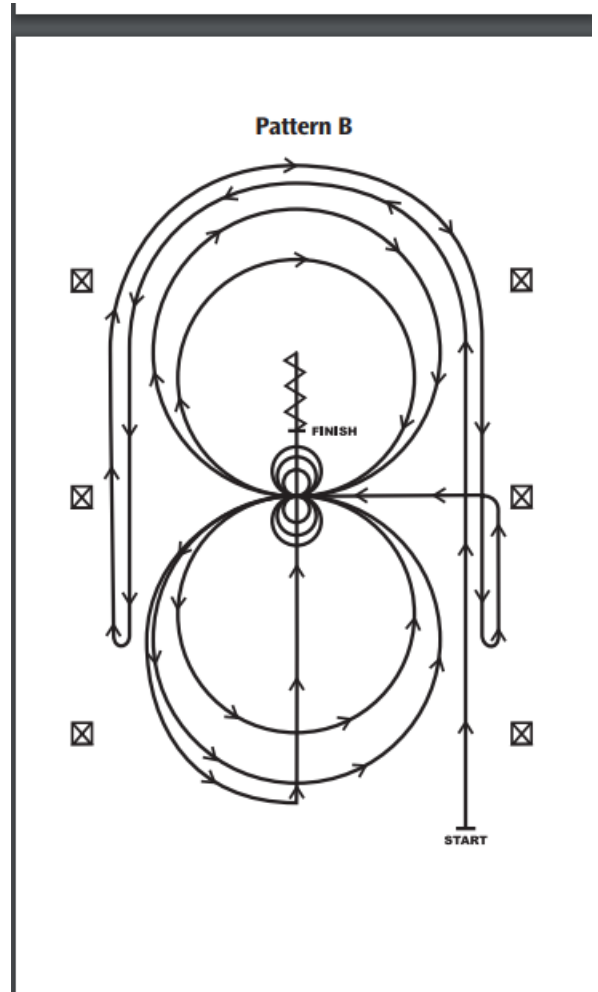

Ranch Horse Division

Note: These classes may be held at a specialized show, or in conjunction with the normal district show.

1. Refer to Western Judged Division General Rules for acceptable tack, attire and equipment.
2. Exceptions to general tack and equipment rules.
 - Horses of any age may be ridden two handed in a snaffle bit or in a bosal hackamore
 - No hoof polish
 - No braided or banded manes or tail extensions, with the exception of ranch roping horses, which may be braided 12-18" in front of the saddle pad.
 - Trimming inside of ears is discouraged
 - Trimming bridle path is allowed, also trimming of fetlocks or excessive (long) facial hair.
 - Equipment with silver should not count over a good working outfit. Silver on bridles and saddles is discouraged.
 - Junior horses shown in a snaffle bit may be ridden with closed reins
 - Horses should have a natural ranch horse appearance from head to tail (no adulterated tails)
3. Optional Equipment
 - Use of a breast collar and a rear cinch is encouraged
 - Rope or riata; if used, the rope or riata must be coiled or attached to the saddle
 - Hobbles attached to the saddle
 - Tapaderos
 - Protective leg boots are allowed
4. Holding the saddle horn with either hand will not be penalized in any ranch class
5. Posting at the extended trot is acceptable

Ranch Ground Handling

Equipment

1. Halters only. Halters and leads may be rope, nylon, or plain leather (no silver). Lead ropes may not have chain. Lead ropes which are permanently attached to halters are allowed. No training sticks or aids are permitted.
2. Braided/banded manes, fake tails and hoof polish/black are not allowed.
3. To assist with event scheduling, the horse may or may not be saddled, as arena schedules permit.

Attire:

Clothing should be neat and clean. Shirts with collar and long sleeves are required, along with western boots. Chinks/chaps and spurs are allowed.

Procedures:

1. This class tests the handler's ability to communicate with the horse from the ground by judging a series of maneuvers that require the horse to yield to pressure – forward, backward, and laterally. Maneuvers are selected to be realistic in their application to everyday training. Exhibitor movements should be workmanlike and efficient and the horse should be obedient and cooperative. Evaluating safe and effective ground handling will take priority to the quality of attire or tack.
2. Cross entering from English and Western Showmanship *is* allowed.

3. Each exhibitor will perform a pattern that will consist of no less than seven (7) of the maneuvers listed below. Exhibitors may be asked to work from both the left and right side of the horse during any of the listed maneuvers (switching hands on the lead is permitted).
 - A. Square horse for inspection; judge will only walk in front of the horse.
 - B. Lead the horse at a walk, jog/trot (or favorite gait for gaited horses only), or back in a straight or curved* line, or a combination of straight and curved* lines.
 - C. Extension of walk or trot.
 - D. Stop
 - E. Answer questions from the judge
 - F. Pivots, moving the forehand up to 270°
 - G. Move the hindquarters, up to 270° (turn on forehand)
 - H. Step away from the horse to the end of the lead while horse remains still
 - I. Lower the horse's head (pulling down on the lead or pressure on the poll)
 - J. Demonstrate a sidepass
 - K. Back the horse while handler remains stationary
 - L. Send horse in a circle (either direction), around a marker, or over a pole.
 - M. Ground tying (handler may be asked to move an object)

(*Curve = any non-straight line including, but not limited to: any change of direction from gradual turns to distinct turns, circles or portions of circles, or multiple curves to create a shape.)
4. Poles, barrels, and cones may be used as markers to define maneuver locations and/or parameters. However, the pattern should not take on the appearance of an "In-hand Trail" class. Hitting/touching/moving these objects will not be scored as penalties, but taken into account when scoring the handler's abilities.
5. Exhibitors may be asked to work from both the left and right side of the horse during any of the listed maneuvers (switching hands on the lead is permitted). Exhibitors may touch the horse to initiate any lateral movement and when asked to lower the horse's head. The judge will recognize added degree of difficulty of not touching the horse and this will be reflected in the maneuver score.

Scoring

6. Scoring will be on the basis of 0 to 100 with 70 denoting an average performance. Judges will assess each maneuver on a scale from -1 ½ to +1 ½ with ½ point increments in between. Points will be added or subtracted from the maneuvers on the following basis, -1 1/2 extremely poor, -1 very poor, -1/2 poor, 0 correct or average, +1/2 good, +1 very good, +1 1/2 excellent
7. Maneuver evaluations and penalty applications are to be determined independently. The following penalties will be applied to each occurrence and be deducted from the final score:
 - A. One-half (½) point
 - (1) Break of gait (walk or trot) up to 1 full stride
 - B. One (1) point

- (1) Touching horse other than when allowed. It is acceptable to touch the horse to sidepass, move the hindquarters, and lower the head.

C. Two (2) points

- (1) Freeze up: complete loss of forward, backward or lateral movement within a maneuver
- (2) Break of gait (walk or trot) for more than 1 full stride
- (3) Use of hand on halter in any manner
- (4) Touching horse with lead (first offense)
- (5) Incorrect or incomplete answer to the judge's question
- (6) Artificial or overdone showing

D. Five (5) points

- (1) Inappropriate Body condition score: Clearly below a 4 or clearly above a 7
- (2) Balking, continued spooking, kicking, biting, rearing, striking
- (3) Failure to complete a maneuver
- (4) Leaving out a maneuver
- (5) Touching horse with end of lead (second offense)

E. Zero (0) score

- (1) Consistent Lameness of AAEP lameness score of 3 or more
- (2) Illegal attire
- (3) Illegal tack
- (4) Abuse
- (5) Performing obstacles in incorrect order

Ranch Horse Riding

1. The purpose of Ranch Horse Riding is to reflect the versatility, attitude and movement of a working horse. The horse's performance should simulate a horse riding outside the confines of an arena and that of a working ranch horse. This class should show the horse's ability to work at a forward, working speed while under control by the rider. The ranch horse should be well-broke, relaxed and quiet at all gaits. Light contact should be rewarded and the horse shall not be shown on a full drape of reins. The overall manners and responsiveness of the horse while performing these maneuvers and the horse's quality of movement are the primary considerations.

2. No horse may cross enter a western pleasure class and a ranch horse riding class at the same show.

3. Class requirements

- Each horse will work individually, performing both required and optional maneuvers.
- The required maneuvers will include the walk, trot, and lope both directions; and the extended trot and extended lope at least one direction; as well as stops, and back.
- Three optional maneuvers may include a side pass, turns of 360 degrees or more, change of lead (simple or flying), walk, trot, or lope over a pole(s); or some reasonable combination of maneuvers that would be reasonable for a ranch horse to perform.
- The maneuvers may be arranged in various combinations with final approval by the judge
- The overall cadence and performance of the gaits should be as those describe in section 7, with an emphasis on forward movement, free-flowing and ground covering for all gaits. Transitions should be performed where designated, with smoothness and responsiveness.

7. Description of Gaits

In all gaits, movement of the ranch pleasure horse should simulate a horse needing to cover long distances, softly and quietly, like that of a working ranch horse. The following terminology shall apply.

- Walk – The walk is a natural, flat footed, four beat gait. The gait is rhythmic and ground-covering. As in all gaits, the horse should display a level, or slightly above level topline with a bright attentive expression.
- Trot – The trot is a natural two-beat gait demonstrating more forward motion than the western jog.
- Extended Trot – The extended trot is an obvious lengthening of the stride with a definite increase in pace. The horse should be moving in a manner as if it were covering a large area on a ranch with an above level topline. Sitting the regular trot and lope is recommended; though standing in the stirrups at the extended trot and extended lope, or posting the extended trot is acceptable. The extended trot may be ridden with the rider either posting or standing in the stirrups to the front of the saddle. Holding the saddle horn is permissible, at this gait, as might be done in open terrain. When transitioning from the extended trot to the lope, it is permissible to take the horse back a bit (collecting) before loping.
- *Natural Gait and Extended Natural Gait – Non-trotting horses should perform their natural gait where a trot is indicated and show a distinctive difference in speed of that gait where an extended trot is asked. The natural gait should be smooth and appear effortless for riding long distances.*
- Lope – The lope is a three beat gait. The lope shall be relaxed and smooth with a natural, forward moving stride.
- Extended Lope – The extended lope is not a run or a race but should be an obvious lengthening of stride, demonstrating a forward, working speed. The horse should display an above level topline with a bright, attentive expression.
- The transition from the extended lope down to the trot is a transition to the seated trot not the extended trot. Therefore an extra cue to achieve this gait is expected. Horses that complete this total transition within three strides calmly and obediently should be rewarded. Horses that attempt to stop or do stop prior to trotting will be penalized.
- Stop (from both lope and trot) – The horse should be in the correct stopping position – both hocks engaged and stopping on the hindquarters.

8. One of the suggested patterns may be used, however a judge may utilize a different pattern as long as all required maneuvers and the three or more optional maneuvers are included. Should a judge use one of his/her own patterns, it is recommended to not have the stop following an extended lope.

9. Scoring

Scoring will be on the basis of zero to infinity, with 70 denoting an average performance. Each obstacle will receive an obstacle score that should be added or subtracted from 70. Each obstacle will be scored on the following basis, ranging from plus 1 1/2 to minus 1 1/2; -1 1/2 extremely poor, -1 very poor, -1/2 poor, 0 correct, +1/2 good, +1 very good, +1 1/2 excellent. Maneuver evaluations and penalty applications are to be determined independently. The following penalties will be applied to each occurrence and be deducted from the final score: Natural ranch horse appearance will also be evaluated ranging from plus 1 ½ to minus 1 ½.

1 pt. penalties

- Too slow/per gait
- Over-bridled
- Out of frame
- Break of gait at walk or jog for 2 strides or less
- Wrong lead or out of lead for 2 strides or less

Three point penalties

- Break of gait at walk or jog for more than 2 strides
- Break of gait at lope except when correcting an incorrect lead
- Wrong lead or out of lead for more than 2 strides
- Draped reins
- Out of lead or cross-cantering more than two strides when changing leads
- Trotting more than two strides when making a simple lead change, during a lope departure or when exiting a rollback
- Severe disturbance of any obstacle

Five point penalties

- Blatant disobedience (bucking, biting, rearing, kicking etc)
- Use of two hands per maneuver (switching from one to two handed) with exceptions listed in western equipment section with snaffles and hackamores. When exhibiting with a snaffle bit or hackamore, an exhibitor may switch between two hands and one hand on the reins at any time.

Off Pattern (OP) Exhibitors going off pattern must always place below exhibitors not incurring a disqualifying fault. Judge shall include OP in the penalty box for each occurrence. The judge shall place exhibitors with one (1) OP above an exhibitor with two (2) OP s regardless of the score

- Eliminates or adds maneuver
- Incomplete maneuver
- Performing maneuvers incorrectly (eg. Turning the wrong way, including an extra maneuver etc.)
- Appearance of an altered tail

Disqualification

- Illegal equipment including hoof black, braided or banded manes, or tail extensions
- Willful abuse
- Major disobedience or schooling

No specific penalties will be incurred for ticks/hits on logs but deduction may be made in maneuver score

No specific penalties will be incurred for over/under spins but deduction may be made in maneuver score

AQHA Ranch Horse Riding

Pattern 1

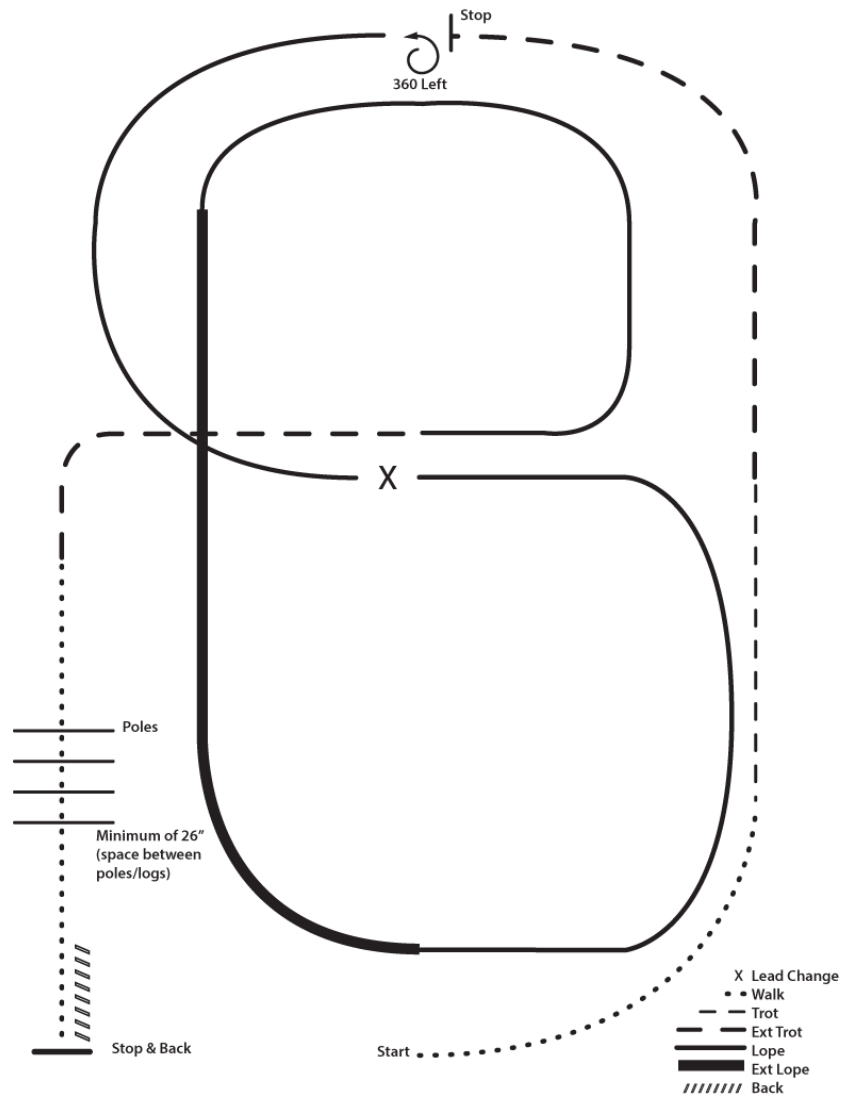

- 1.Walk
- 2.Trot
- 3.Extend the trot, at the top of the arena, stop
- 4.360 degree turn to the left
- 5.Left lead ½ circle, lope to the center
- 6.Change leads (simple or flying)
- 7.Right lead ½ circle
- 8.Extended lope up the long side of the arena (right lead)
- 9.Collect back to a lope around the top of the arena and back to center
- 10.Break down to an extended trot
- 11.Walk over poles
- 12.Stop and back

AQHA Ranch Horse Riding

Pattern II

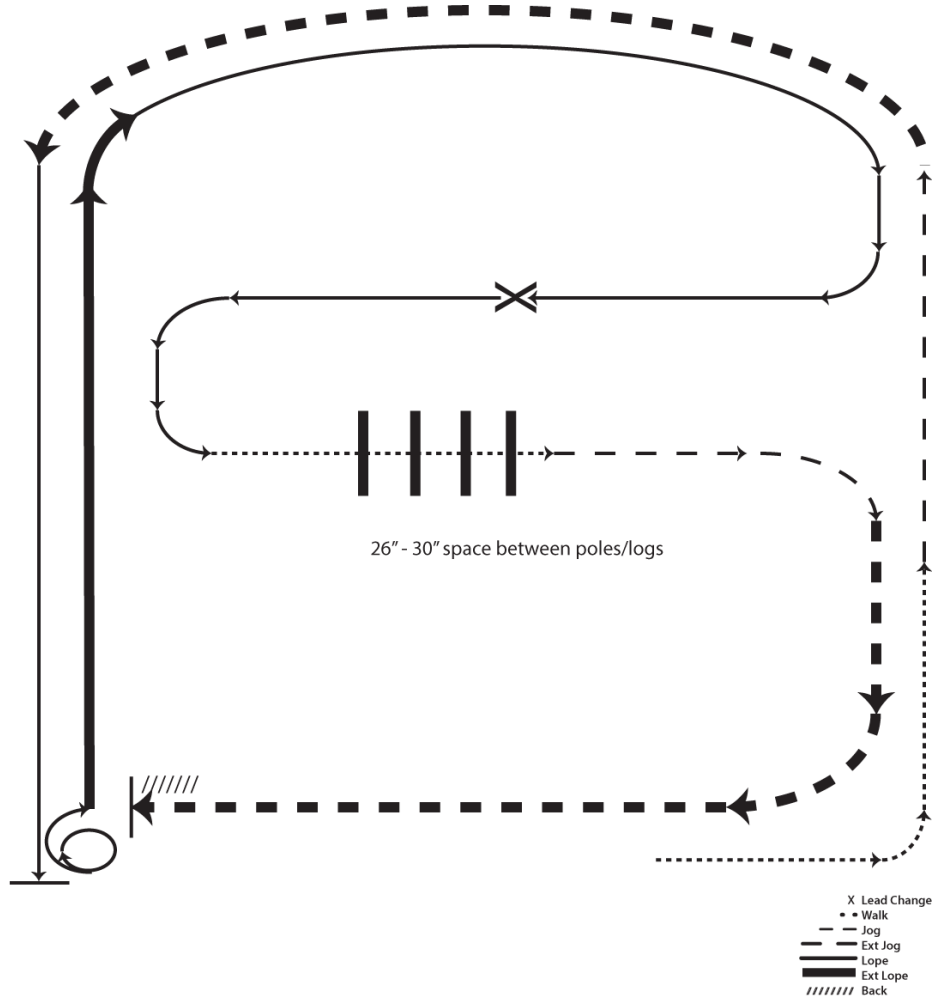

1. Walk
2. Trot
3. Extended trot
4. Left lead lope
5. Stop, 1 ½ turn right
6. Extended lope
7. Collect to working lope-right lead
8. Change leads (simple or flying)
9. Walk
10. Walk over logs
11. Trot
12. Extended trot
13. Stop and back

AQHA Ranch Horse Riding

Pattern III

1. Walk to the left around corner of arena
2. Trot
3. Extend alongside of the arena and around the corner to center
4. Stop, side pass right
5. 360 degree turn to each direction (either way 1st)
6. Walk
7. Trot
8. Lope left lead
9. Extend the lope
10. Change leads (simple or flying)
11. Collect to the lope
12. Extend trot
13. Stop and back

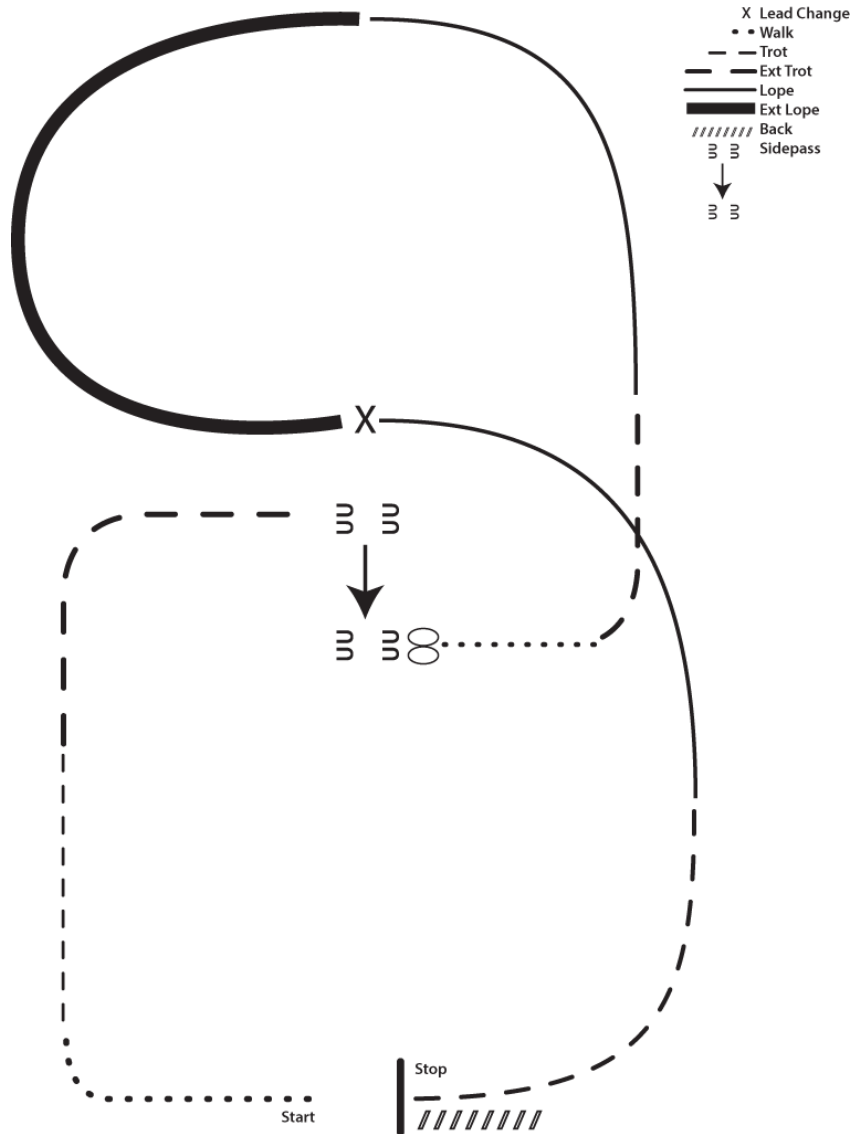

AQHA Ranch Horse Riding

Pattern IV

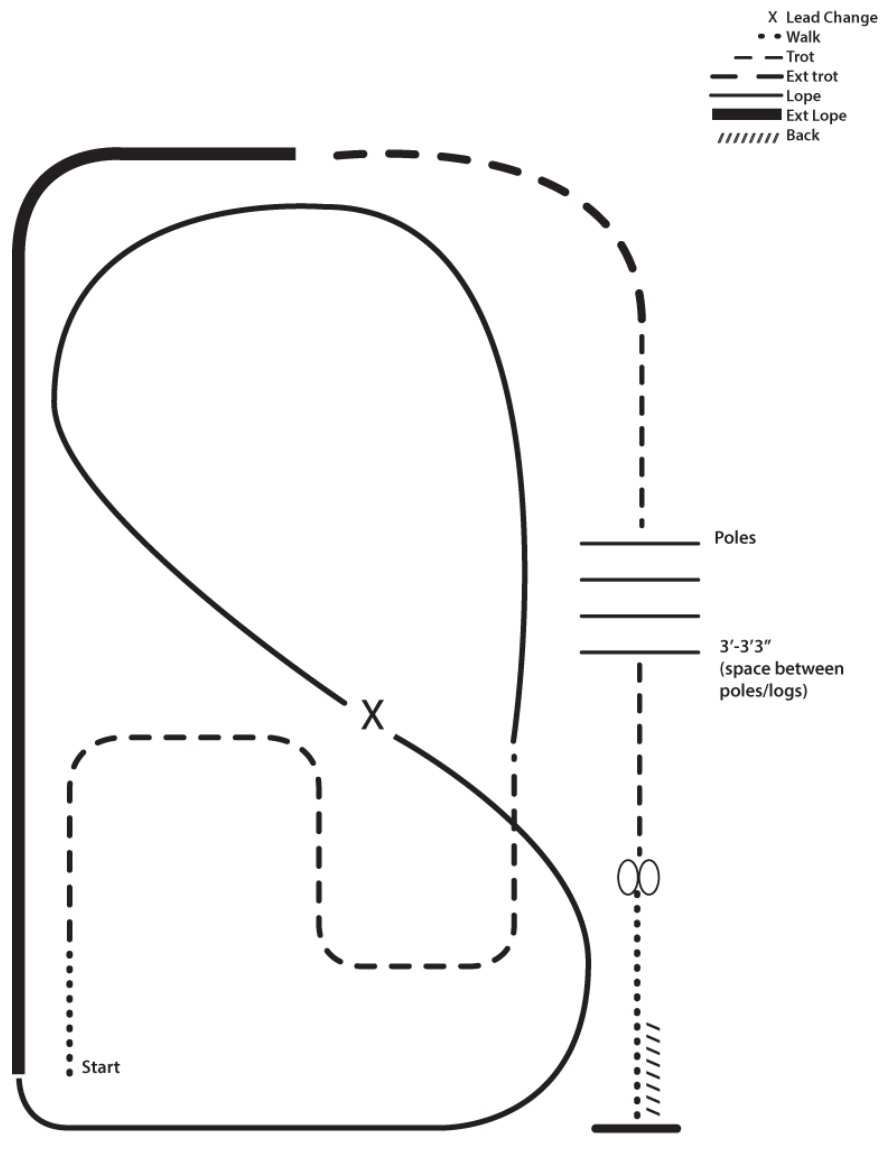

1. Walk
2. Trot serpentine
3. Lope left lead around the end of the arena and then diagonally across the arena.
4. Change leads (simple or flying) and
5. Lope on the right lead around end of the arena
6. Extend lope on the straight away and around corner to the center of the arena
7. Extend trot around corner of the arena
8. Collect to a trot
9. Trot over poles
10. Stop, do 360 turn each direction (either direction 1st)
11. Walk, stop and back

AQHA Ranch Horse Riding

Pattern V

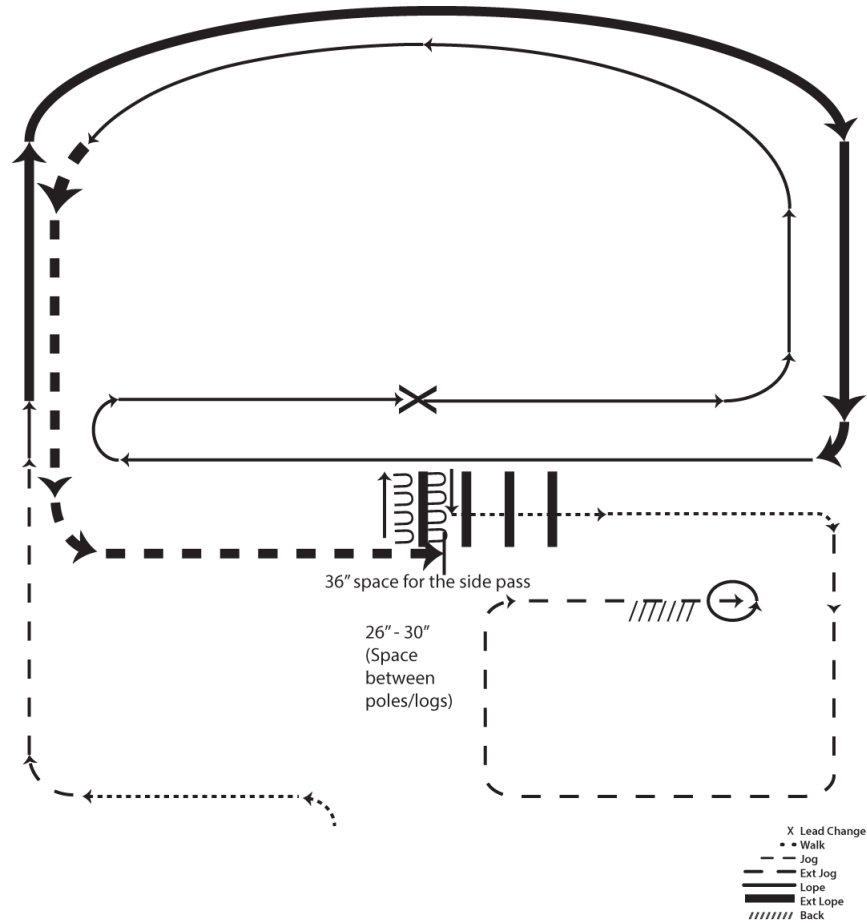

1. Walk
2. Trot
3. Extended lope right lead
4. Lope right lead
5. Change leads (simple or flying)
6. Lope left lead
7. Extended trot
8. Stop, side pass left, side pass right, ½ way
9. Walk over logs
10. Walk
11. Trot square
12. Stop, 360 turn left, back

AQHA Ranch Riding Pattern 6

RANCH RIDING - PATTERN 6

LEGEND

.....	Walk
.....	Extended Walk
- - - -	Trot
- - - -	Extended Trot
————	Lope
————	Extended Lope
//////	Back
∩	Lead Change

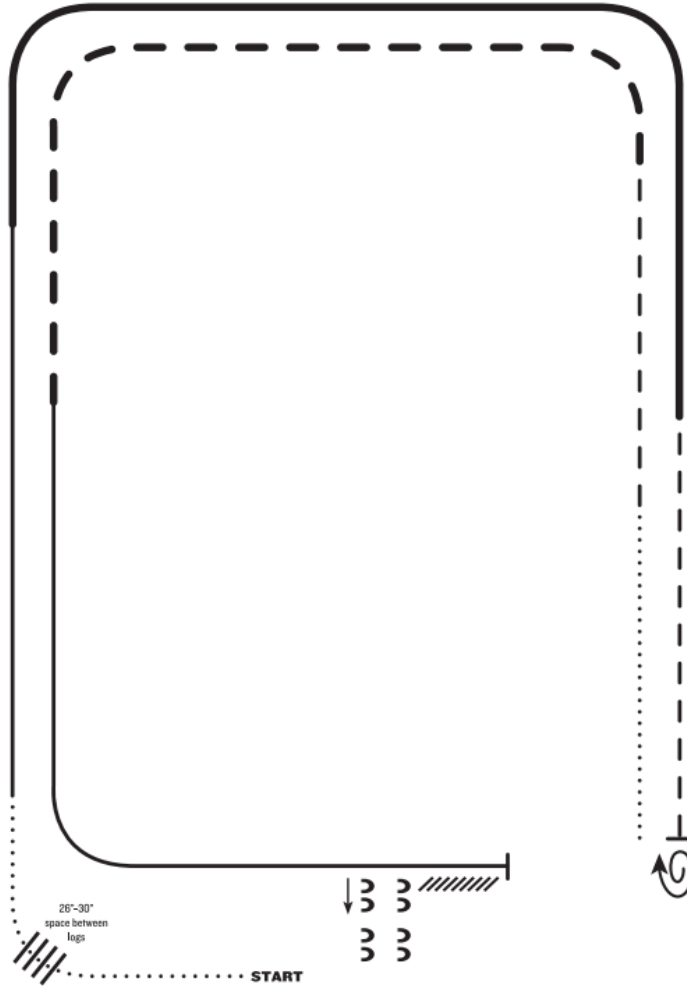

1. Walk
2. Walk over logs
3. Lope right lead
4. Extended lope right lead
5. Trot
6. Stop, 1 1/2 turn right
7. Walk
8. Trot
9. Extended trot
10. Lope left lead
11. Stop and back
12. Side pass right

Note: The drawn description of this pattern is only intended for the general depiction of the pattern. Exhibitors should utilize the arena space to best exhibit their horses.

AQHA Ranch Riding Pattern 7

RANCH RIDING - PATTERN 7

LEGEND

.....	Walk
.....	Extended Walk
- - - -	Trot
- - - -	Extended Trot
————	Lope
————	Extended Lope
//////	Back
	Lead Change

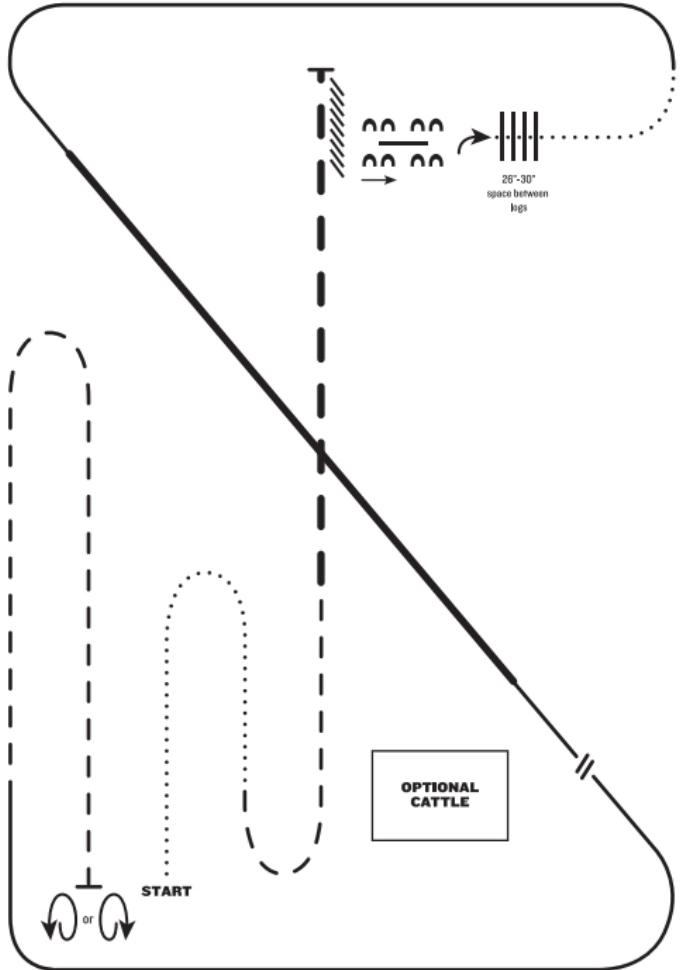

1. Walk
2. Trot
3. Extended trot
4. Stop and back
5. Side pass right over log
6. 1/4 turn right, walk over logs
7. Walk
8. Lope left lead
9. Extended lope left lead
10. Collect lope, change leads (simple or flying)
11. Lope right lead
12. Trot
13. Stop, one 360° turn either direction

Note: The drawn description of this pattern is only intended for the general depiction of the pattern. Exhibitors should utilize the arena space to best exhibit their horses.

AQHA Ranch Riding Pattern 8

RANCH RIDING - PATTERN 8

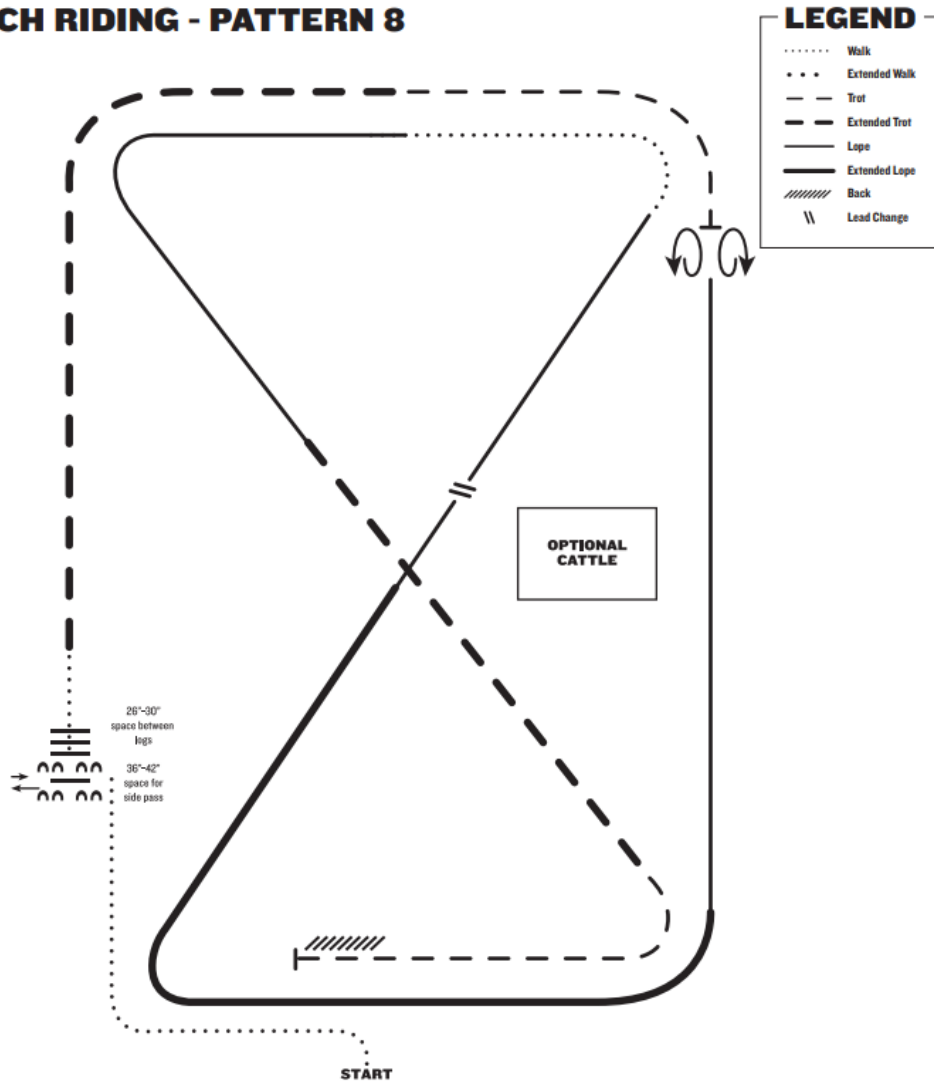

- I. Walk
2. Side pass left across first log, side pass 1/2 way to right
3. Walk over logs
4. Extended trot
5. Trot
6. Stop, 360° turn each direction (either direction 1st) (L-R or R-L)
7. Lope right lead
8. Extended lope right lead
9. Collect lope, change leads (simple or flying), continue lope left lead
10. Walk
- II. Lope left lead
12. Extended trot
13. Trot
14. Stop and back

Note: The drawn description of this pattern is only intended for the general depiction of the pattern. Exhibitors should utilize the arena space to best exhibit their horses.

AQHA Ranch Riding Pattern 9

RANCH RIDING - PATTERN 9

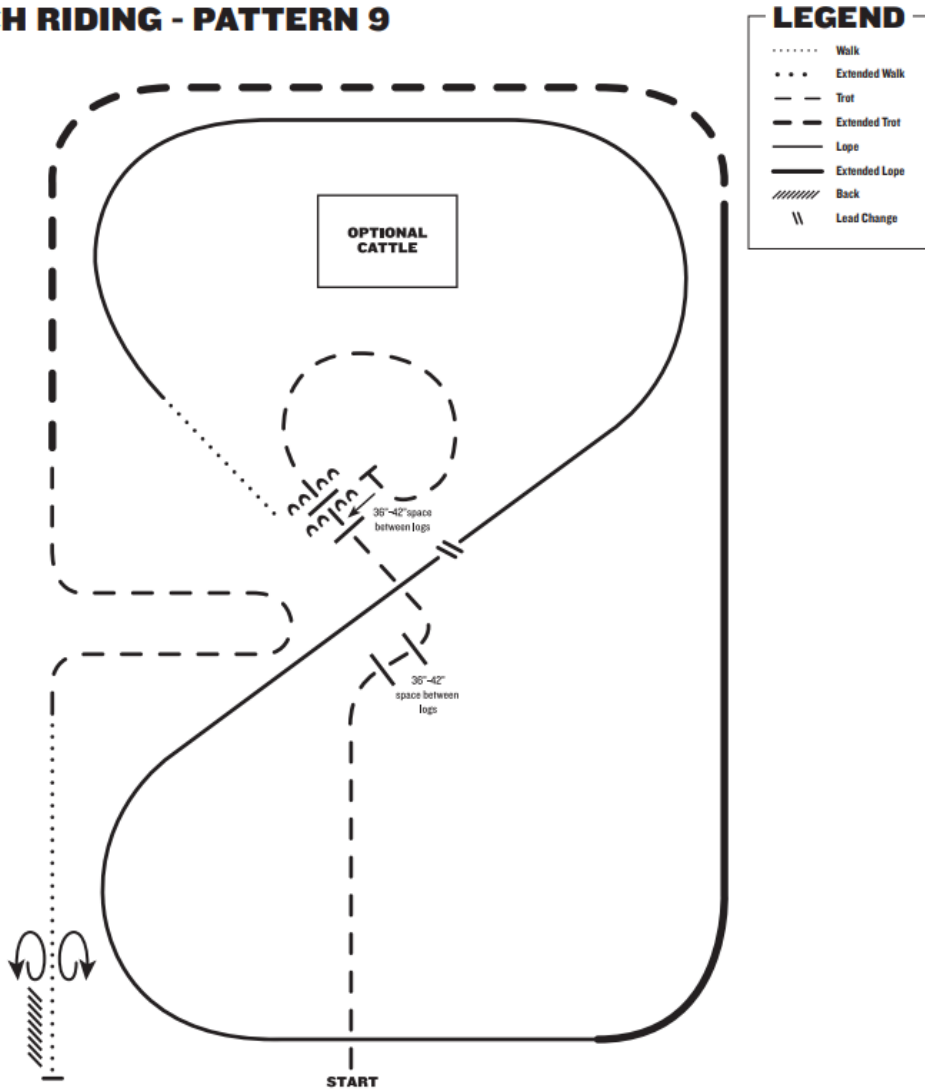

- I. Trot
2. Trot over two sets of logs
3. Trot circle, stop and side pass left over log
4. Walk
5. Lope right lead
6. Change leads (simple or flying)
7. Lope left lead
8. Extended lope left lead
9. Extended trot
10. Trot
11. Walk
12. Stop and back
13. 360° turn each direction (either direction 1st) (L-R or R-L)

Note: The drawn description of this pattern is only intended for the general depiction of the pattern. Exhibitors should utilize the arena space to best exhibit their horses.

Ranch Trail

1. General Rules.

This class should test the horse's ability to cope with situations encountered while being ridden through a pattern of obstacles generally found during the course of everyday ranch work. The horse/rider team is judged on the correctness, efficiency, and pattern accuracy with which the obstacles are negotiated, and the attitude and mannerisms exhibited by the horse. Judging emphasis is on identifying the well broke, responsive, and well-mannered horse which can correctly navigate and negotiate the course. The ideal ranch trail horse should have a natural ranch horse appearance from head to tail in each maneuver.

a. Refer to Western Judged Division General Rules and Ranch Riding rules for acceptable tack, attire and equipment. Except for horses shown with a hackamore or snaffle, only one hand may be used on the reins, except that it is permissible to change hands to work an obstacle. Failure to do so will result in penalties. While horse is in motion, rider's hands shall be clear of horse and saddle.

b. Horses may cross enter Trail and Ranch Trail at the same show.

CLASS REQUIREMENTS/PROCEDURES:

a. The ranch trail course will include no less than six and no more than nine obstacles. It is mandatory that the horse be asked to walk, trot and lope during the course. Horse to be shown at a ground-covering walk, working trot and lope. The horse should perform with a reasonable loose rein that maintains contact with the horse. Walk can be part of obstacle score or be scored with the approaching obstacle. Trot must be at least 35 feet and score with approaching obstacle. Lope must be lead-specific, at least 50 feet and score with approaching obstacle. Care must be exercised to avoid setting up any obstacles that may be hazardous to the horse or rider.

b. When setting courses, management will be mindful that the idea is not to trap a horse/rider team or eliminate it by making an obstacle too difficult. All courses and obstacles are to be constructed with safety in mind so as to reduce the risk for accidents. Show committee shall have the option of setting up the trail course to best fit the arena conditions. An outdoor course is recommended if appropriate terrain is available. Each single-performance event can be time consuming, especially with large classes, so it is imperative that time restrictions are placed on this class. The show committee, either through a pilot run or estimation, shall select a course that has a continuous and positive flow that can be negotiated in four minutes or less.

c. Judges must walk the course and have the right and duty to alter the course if it is not in keeping with the intent of the class. Judges may remove or change any obstacles they deem unsafe, non-negotiable or unnecessarily difficult. Any time a trail obstacle becomes unsafe during a class, it shall be repaired or removed from the course. If the course cannot be repaired and some horses have completed the course, the score for that obstacle shall be deducted from all previous draws in that class.

d. The course must be designed using the mandatory obstacles and maneuvers plus optional obstacles. Combining two or more of the obstacles is acceptable.

e. The ranch trail class contains a course with a minimum of six obstacles and is designed to show a horse's ability and willingness to perform several tasks that might be asked of it during the course of a normal day's ranch work. Whenever possible realistic or natural obstacles are encouraged (branches, logs, wooden fence posts). A horse will be rewarded with higher credit for performing these gaits on the correct lead and with an alert attitude. All obstacles must meet the approval of the judge.

f. All courses and obstacles are constructed with safety in mind as to eliminate any possible accidents. **PROHIBITED OBSTACLES:** Tarps, water obstacles with slick bottoms, PVC pipe used as a jump or walk over, tires, rocking or moving bridges, logs elevated in a manner that permits such to roll in a dangerous manner.

g. An exhibitor who does not perform an obstacle or performs an obstacle incorrectly is assessed a 10 point penalty and cannot place over another exhibitor that performs the course correctly.

2. Mandatory Obstacles:

a. Opening, passing through and closing a hinged swinging gate (not a rope gate): Use gate that will not endanger horse or rider and requires minimum side-passing.

b. Ride over obstacles on the ground (usually logs). Walk, trot or lope may be used but only one gait is required. - Walk-overs: Walk over no more than five logs no more than 10 inches high and spacing between 26 – 30 inches. The formation may be straight, curved, zigzagged or raised. - Trot-overs: Trot over no more than five logs no more than 10 inches high. The space between logs or poles should be 36-42 inches. The formation can also be straight, curved, zigzagged or raised. - Lope-overs: Lope over no more than five logs no more than 10 inches high. The space between logs should be 6 to 7 feet. The formation can also be straight, curved, zigzagged or raised.

c. Ride over wooden bridge: Bridge should be sturdy, safe and negotiated at a walk only. Heavy plywood lying flat on the ground is an acceptable simulation of a bridge. Suggested minimum width shall be 36 inches wide and at least 6 feet long.

d. Backing obstacles: Backing obstacles are to be spaced at a minimum of 28 inches. If elevated, 30 inch spacing is required. Back through and around at least three markers. Back through L, V, U or straight or similarly shaped course which may be elevated no more than 24 inches.

e. Side-pass obstacle: Any object which is safe and of any length may be used to demonstrate responsiveness of the horse to leg signals. Raised side pass obstacles should not exceed 12 inches.

f. Stationary steer- This obstacle is used to show the willingness of the horse to have a rope thrown from its back. The judge will give credit to the horse that stands quietly while the contestant makes the swing and throw at the stationary steer. Shying from the rope will be penalized, but missing the stationary steer will not be penalized. Rider must provide their own rope for this obstacle. Rope may be carried in hand, over the saddle horn, or affixed to the saddle. At the completion of this obstacle, contestant may coil rope and keep for the remainder of the class, or drop the rope without penalty.

3. Optional Obstacles

a. Water hazard. The horse should show willingness to cross a small ditch or shallow pond (or simulated water obstacle)

b. Hobble or ground tie (contestant's option). The horse shall remain in place while the rider dismounts and performs a normal ranch task such as moving a rail, moving a bale of hay, etc. If riding with a mecate or romal reins, the reins must be draped/half-hitched over saddle horn and a tie rein or get down rope will be placed on the ground or the horse must be hobbled. In riding with split reins only one rein is required to be placed on the ground. *If used, this must be the last obstacle of the course and must be held in an enclosed arena.*

c. Put on and remove a slicker. Rider approaches slicker, removes slicker from holder, puts on slicker, removes slicker and replaces slicker to holder.

d. Remove, carry and replace item. Requires the exhibitor to carry or remove an item that is used every day on horseback such as mail from a mailbox, sack, rope, etc.

e. A jump obstacle whose center height is not less than 14 inches high or more than 25 inches high. Holding the saddle horn is permissible for this obstacle

f. *Dismounting. The horse shall remain quiet while the rider dismounts. No penalty will be assessed for horse shifting to balance. A one point penalty for one to two steps, a three point penalty for three to four steps and a five point penalty for five or more steps will be assessed. (Remounting may only be required for ages 15-19.) The horse*

should remain still and quiet as the rider remounts, leaving a loose rein. Exhibitors have the option of using a mounting block to remount. Once the rider is settled into the saddle and is still, he or she may move the horse forward.

g. Pick up front feet – the rider must be able to dismount and pick up one or both front feet in an easy, time efficient manner. May be used in succession with ground tie so rider only dismounts once per course. Riders in age group 15-19 may be required to remount.

h. *Log drag – Horse must be willing to drag a log for a short distance, either in a straight line or around a set pattern. Rope should be dallied (half or full) around the saddle horn and not tied hard and fast.*

i. Only live or stuffed animals which would normally be encountered in an outdoor setting may be used but not to be used in an attempt to spook a horse.

j. Trot through cones spaced a minimum of 6 feet apart.

k. Cross natural ditches or ride up embankments.

l. Step in and out of obstacle.

m. Open gate on foot.

n. Walk through brush.

o. Lead at the trot.

4. Scoring

CREDITS AND PENALTIES. All runs begin upon entering the area of competition and any infractions are subject to penalty at that time (such as two hands on the reins, using either hand to instill fear or praise, etc.). The rider has the option of eliminating any obstacle, however this will result in being off pattern (OP) and the horse/rider team may not place above others who have completed the pattern correctly. A judge may ask a horse to pass on an obstacle after three refusals or at any time for safety concerns.

Credit is given to horse/rider teams who negotiate the obstacles correctly and efficiently. Horses should receive credit for showing attentiveness to obstacles and ability to negotiate through the course when the obstacles warrant it while willingly responding to rider's cues on more difficult obstacles. Quality of movement and cadence should be considered part of the maneuver score for the obstacle. Maneuver evaluations and penalty applications are to be determined independently. The following penalties will be applied to each occurrence and be deducted from the final score:

a. Scoring will be on the basis of zero to infinity, with 70 denoting an average performance. Each obstacle will receive an obstacle score that should be added or subtracted from 70. Each obstacle will be scored on the following basis, ranging from plus 1 1/2 to minus 1 1/2; -1 1/2 extremely poor, -1 very poor, -1/2 poor, 0 correct, +1/2 good, +1 very good, +1 1/2 excellent. Obstacle scores are to be determined and assessed independently of penalty points. Natural ranch horse appearance will also be evaluated ranging from plus 1 ½ to minus 1 ½.

b. Penalties: Obstacle evaluations and penalty applications are to be determined independently. The following penalties will be applied to each occurrence and be deducted from the final score:

One (1) Point

- Each bite of or hit of or stepping on a log, pole, cone or any component of the obstacle.
- Incorrect or break of gait at walk or jog for two strides or less.
- Incorrect number of strides, if specified

- Horse taking one to two steps during dismounting/remounting/ground tying (except shifting to balance)
- over-bridled (per maneuver)
- out of frame (per maneuver)
- both front or hind feet in a single-stride slot or space at a walk or trot
- skipping over or failing to step into required space
- split pole in lope-over

Three (3) Point

- Incorrect or break of gait at walk or jog for more than 2 strides.
- Out of lead or break of gait at lope (except when correcting an incorrect lead).
- Knocking down an elevated pole, cone, barrel, plant obstacle, or severely disturbing an obstacle.
- Stepping outside the confines of or stepping off or out of an obstacle with designated boundaries with one foot that has entered an obstacle, including missing one element of an obstacle on a line of travel with one foot.
- Falling or jumping off or out of a bridge or a water box with one foot once the horse has got onto or into that obstacle
- Three to four steps taken while dismounting/remounting/ground tying
- Draped reins

Five (5) Point

- Letting go of gate, or dropping lariat except after completion of the roping obstacle.
- Dropping slicker, log rope or object required to be carried on course.
- First or second cumulative refusal, balk, or attempting to evade an obstacle by shying or backing more than 2 strides away.
- Five or more steps taken while dismounting/remounting/ground tying
- Blatant disobedience (including kicking out, bucking, rearing, striking, balking, freezing up).
- Stepping outside the confines of, falling or jumping off or out of an obstacle with designated boundaries (ie. back through, 30 degree box, side pass) with more than one foot once the foot has entered the obstacle; includes missing one element of an obstacle on a line of travel with more than one foot
- Use of either hand to instill fear or praise.
- Use of two hands per maneuver (switching from one to two handed) with exceptions listed in western equipment section with snaffles and hackamores, changing of hands on reins unless changing hands to work an obstacle, incorrect use of romal (see western equipment section)
- Use of more than one finger between reins (index finger only between reins) or romal reins
- Spurring in front of cinch

Off Pattern (OP) Exhibitors going off pattern must always place below exhibitors not incurring a disqualifying fault. Judge shall include OP in the penalty box for each occurrence. The judge shall place exhibitors with one (1) OP above an exhibitor with two (2) OP s regardless of the score.

- Not performing an obstacle or performing an obstacle incorrectly
- Performing the obstacles other than in the specified order
- For a particular obstacle, the third cumulative refusal, balk, or evading an obstacle by shying or backing, (This penalty is in addition to the two -5 penalties received for the first and second cumulative refusal.) Judge is allowed to motion rider on after third refusal on an obstacle. Judge's decision to motion a rider on is at judge's discretion and not subject to protest.

- Failure to ever demonstrate designated gait between/within an obstacle
- Eliminating or adding a maneuver
- Repeated blatant disobedience, and failure to dally and remain dallied
- Failure to open and shut gate, or failure to complete gate

Faults, which occur on the line of travel between obstacles, scored according to severity:

Head carried too low (tip of ear below the withers consistently), over-flexing or straining neck in head carriage so the nose is carried behind the vertical consistently, excessive nosing out, and opening mouth excessively between obstacles. Repeated or excessively touching the horse on the neck to lower the head between or during obstacles.

Disqualification for Course (Non-placing score):

- No attempt to perform an obstacle.
- Riding outside designated boundary marker of the course, such as leaving the arena or area that the trail pattern is set up.
- Equipment failure that delays completion of pattern.
- Fall of horse or rider.
- Excessive schooling, pulling, turning, stepping or backing anywhere on course
- Judge has the authority to excuse and/or disqualify any horse deemed unsafe or out of control. An exhibitor will be excused from the class (disqualified) if there is a tack or equipment breakage that the judge feels is a safety hazard.
- Lameness, excessive schooling, abuse

Ranch Roping

1. General Rules.

a. Refer to Western Judged Division General Rules and Ranch Riding rules for acceptable tack, attire and equipment. Western style, curb bit with split reins or a romal with a ½ inch or wider; leather or flat chain chinstrap for any age horse. Horses of any age may be ridden in bosal hackamore with split rein or single rein Mecate or a ring snaffle with split reins or mecate single rein. For the safety of the rider, split reins may be tied or roping reins may be used in the 14 and under aged division.

b. The purpose of this class is to show the ability of the horse and rider's skill in handling cattle as if they were doctoring injured or sick cattle. Cattle should be handled as calmly and slowly as possible. The contestant does not have to separate the cow from the herd and should not receive credit for separation from the herd. If the cow is separated from the herd there should be no excessive running or cutting of the cow.

2. Class procedures:

a. This is a judged event with a 2 minute time limit. There shall be a 30 second warning given prior to the end of the run.

b. The arena for this event will be shortened with the addition of portable panels. The exhibition area should be normal width of the arena (usually 100 to 150') with the length shortened to approximately 75' to 80'.

c. Horse and rider must start from an entrance gate which will be opposite from where ten (10) cows are held as a herd with each bearing a number 0 - 9. A random draw will be used to select the calf to be roped, which will be announced to the contestant when the horse enters the arena gate.

d. The contestant should make a desired catch, position their horse in an appropriate manner and dally up. The rope must be thrown and the contestant may rebuild and throw an unlimited number of loops. No credit will be given for additional loops after a successful catch of any part of the animal. The contestant must make a legal catch around the neck if polled cattle, or around the neck, both horns or half head if using horned cattle of the designated cow and dally up. When the cow breaks free from the honda, the Flag Judge will signal the end of the run. The honda on the rope used must be of a breakaway design. *Note: the youth does not have to complete a catch to receive a score.*

e. The show committee will provide 2 herd holders. The sole duty of the herd holders is to settle the cattle between runs.

3. Scoring

a. Scoring will be on the basis of 0 to 100, with 70 denoting an average performance. Each maneuver will be scored from a plus **three** to minus **three** in ½ point increments. -3 extremely poor, -2 very poor, -1 poor, 0 average or correct, +1 good, +2 very good, +3 excellent. Maneuvers will consist of: 1. Ability to sort and move cow either within or out of the herd into roping position 2. Ability to rope out of the herd without disturbing other cattle. 3. Dallying- Correct horse position and proper dallying technique 4. Stopping horse in position and square to cow 5. Ability to manage coils. 6. Difficulty of a throw that results in a successful catch.

b. Penalties

Three (3) point penalty:

- Pawing or biting cattle
- Multiple loop run (penalty may be assessed for each rebuild with a maximum of 15 points taken)
- Loss of cow (re-cut in the herd) Exception: if a cow returns to a herd after a loop has been thrown, an additional three point penalty for loss of cow will NOT be assessed.

Five (5) point penalty:

- Excessive running/scattering of the herd
- Blatant disobedience including kicking, bucking, biting, rearing or striking
- Including a front leg in the loop
- Running into or over cattle
- Use of two hands per maneuver (switching from one to two handed) with exceptions listed in western equipment section with snaffles and hackamores; switching between one and two hands is allowed with hackamores and snaffle bit is allowed.

Ten (10) point penalty:

- Roping the wrong cow
- Roping more than 1 cow with the same loop
- Roping any portion of the cow past the shoulder (for example: around the flank)
- Roping any portion of the cow without the loop passing over the head (for example: roping by only one or both front or hind feet)

Twenty (20) point penalty: Avoids disqualification but must be placed below any contestant who performs correctly

- Loss of rope
- Failure to catch

*ONP (obstacle not performed): If exhibitors fail to attempt to rope by throwing the loop, this will result in placement below all exhibitors who attempted to rope.

Zero (0) score / DQ:

- Schooling

- Whipping or hitting horse with rope
- Fall to the ground horse and/or rider
- Any horse or rider that is out of control, thus endangering rider, horse or cow
- The judge may blow their whistle at any time to terminate the work, a score of zero will be charged if the work is not complete at that point.

Boxing

1. General Rules.

a. Refer to Western Judged Division General Rules and Ranch Riding rules for acceptable tack, attire and equipment. Unless riding in a snaffle or hackamore, only one hand may be used on reins and hands must not be changed or the rider will acquire a penalty. Standard Western Judged Division bit rules will apply.

b. The Working Cow Horse (boxing only for 4-H) class is based on the traditional vaquero training techniques used to develop the most highly schooled of all cow horses, the bridle horse. The training begins in a snaffle bit, progresses to a hackamore and then the two-rein on the way to the bridle. This method of training, which takes years rather than months, is geared to helping a horse reach his maximum level of performance, from the working ranch to the competitive arena. Both the cow work portion of this event and the reined work portion are mandatory. Scoring emphasis on the cow work portion shall be based on the horse maintaining control of the cow at all times, exhibiting superior cow sense and natural cow working ability without excessive reining or spurring. The greater the difficulty of the run, the more credit should be given. The difficulty may be due to the extreme speed or stubbornness of the cow, or the cow's reluctance to move down the fence when sufficiently driven by the contestant. The most controlled cow work with the highest degree of difficulty should be marked the highest. Failure of an exhibitor to attempt to complete the cow work portion of the class, as well as the reined work, will result in the exhibitor not being considered an entry in the class. A horse that attempts to complete the cow work and has not been disqualified will be scored accordingly at the judge's discretion. A horse going off pattern in the reined work will receive a score of zero. A horse that attempts both the reined work and the cow work portion may be placed, even if disqualified in one portion of the class. (Example: If a horse is disqualified and receives a 0 score for the reined work, but scores a 70 for the cow work, its total score would be a 70 and the horse would be eligible for placing.) If however, a horse is both disqualified in the reined work and receives a score of 60 in the cow work will not be able to place. In addition, the fall of a horse and rider being judged shall be cause for disqualification and not eligible to be placed.

c. Characteristics of a good working cow horse include;

- good manners
- shifty, smooth and having its feet under it at all times; when stopping, hind feet should be well under it
- a soft mouth and should respond to a light rein, especially when turning
- head should be maintained in its natural position
- work at reasonable speed and still be under control of the rider

2. Class Procedures

Boxing consists of a reining pattern and single cow work (boxing) on the end of the arena. The goal of this class is to introduce the rider to the "boxing" phase of the cow work. Judging begins when the contestant enters the arena. There shall be no schooling between the completion of the rein work and the cow work, or between cows if a new cow is awarded. The penalty for this is -0-. Each contestant upon receiving a cow in the arena, shall hold that cow on the prescribed end of the arena for 50 seconds, demonstrating the ability of the horse and rider to control the cow. It is legal to hold the reins and romal in one hand (rein hand) while boxing the cow. Time shall begin when the gate closes behind the cow after being let into the arena. The announcer or judge will signal the completion of the 50 seconds with a whistle or horn.

- a. An approved pattern from AQHA approved working cow horse patterns will be used. Contestant will cause his horse to travel at the gait indicated for each part of the pattern.
- b. The judge should take into consideration the size of the arena, condition of ground and the disposition and degree of difficulty exhibited by the cattle worked.

- c. Horse should keep working until judge blows whistle. If exhibitor quits working before the judge blows the whistle, a score of 0 will be given.
- d. *If exhibitor loses the cow beyond the center marker, the judge will blow the whistle ending the run. The contestant will receive a score of 60 for that run.*
- e. If time and number of cattle permit, the judge may, at this discretion, award new cattle, to enable the contestant to show his horse's ability on the cow, based on the following criteria: Two whistles to award a new cow.
 - The cow won't or can't run
 - The cow won't leave the end of the arena
 - The cow is blind or won't yield to the horse
 - The cow leaves the arena

3. Scoring

a. Reined work: See Reining scoring procedures.

Exceptions to Reining scoring procedures (Note: this is not an inclusive list of penalties):

½ point penalties

- Trotting out of a circle or a rollback up to three strides (6 steps)

One (1) point penalties

- a one point penalty will be applied for scotching or anticipating a stop
- slipping a rein
- *Simple lead changes are allowed, but are limited to three strides of jogging (or 6 steps). Beyond three strides, but up to ½ a circle receives a 1 point penalty*

Two (2) point penalties

- Failure to stop before executing a lope departure in trot in patterns

Three (3) point penalties

- Trotting beyond half a circle to change leads results in a three point penalty
- Backing beyond two strides where not called for in the pattern (up to four steps) *instead of a 0 score*
- Incorrect pattern in regards to spins only (completing an incorrect number of spins will receive a three point penalty rather than a 0 score)

Note: there is no five point penalty for holding the saddle horn or use of hand to instill fear or praise.

Five (5) point penalties

- Use of two hands per maneuver (switching from one to two handed) with exceptions listed in western equipment section with snaffles and hackamores. If riding with a snaffle bit or hackamore it is acceptable to switch between one and two hands.

b. Boxing: Scoring will be on the basis of 60-80, with 70 denoting an average performance. The judge may blow the whistle at any time to terminate the work. A score of zero will be given if the work is not complete at that time. Each work will be limited to 50 seconds.

a. Credits

- maintaining control of the cow at all times
- maintaining proper position
- degree of difficulty
- eye appeal
- time worked

b. Faults

- exaggerated opening of mouth
- hard or heavy mouth
- nervous throwing of head
- lugging on bridle
- halting or hesitation while being shown, particularly when being run out, indicating anticipation of being set up
- losing a cow or being unable to finish a pattern because of a bad cow, the contestant should be penalized at the judge's discretion

c. Penalties

One(1) point

- Loss of working advantage
- Working out of position
- Using corner to turn cow
- Changing sides of arena
- Running one horse length past cow

Three (3) points

- Loss of control and cow leaves end of arena

Five(5) points

- Spurring or hitting in front of cinch at anytime
- Use of two hands per maneuver (switching from one to two handed) with exceptions listed in western equipment section with snaffles and hackamores
- Blatant disobedience defined as bucking, biting, rearing, striking or obviously insubordinate

Score 60

- Turn tail
- Loss of cow beyond center marker

Disqualified/Score 0

- Out of control
- Bloody mouth/inhumane treatment of the horse
- Illegal equipment
- Leaving working area before pattern is complete
- Fall of horse or rider
- Schooling between reined work and cow work
- Schooling between cows, if a new cow is awarded
- Failure to quit working a cow after a new cow has been awarded
- Failure to quit working a cow after a run has been whistled off

Cow Horse
Pattern 1

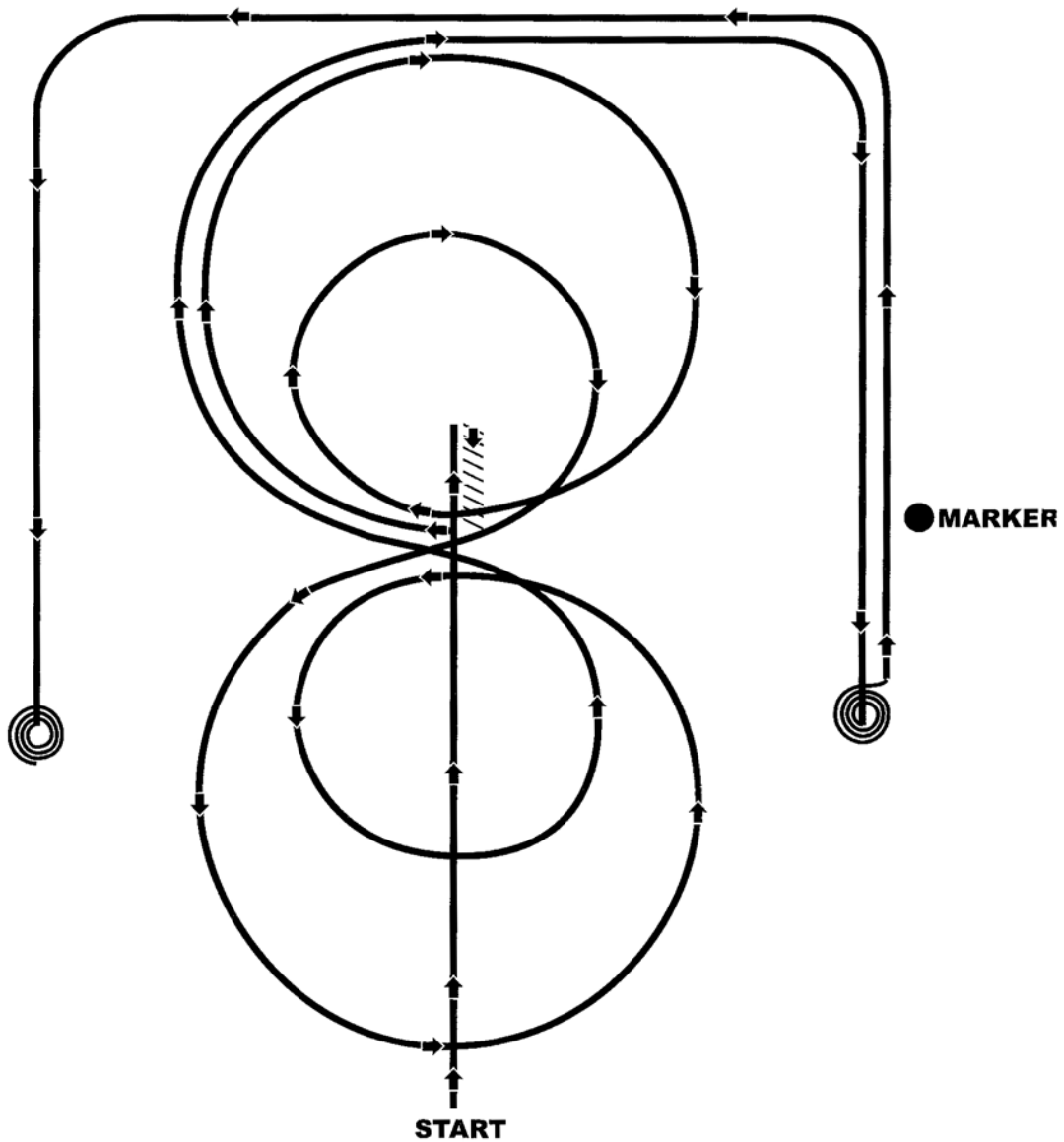

PATTERN 1

1. Start at end of arena. Run down middle past center marker to a sliding stop.
2. Back at least ten feet to center. $\frac{1}{4}$ turn to left.
3. Pick up right lead, large fast circle, small, slow circle
4. Change leads to left, large fast circle, small slow circle.
5. Change leads to right, do not close this circle
6. Run around end of arena and down the side (approximately 20 feet from fence) past center mark and come to a sliding stop.
7. Complete 3 $\frac{1}{2}$ spins to the right.
8. Continue back down side and end of arena to other side (approximately 20 feet from fence) go past center marker and come to a sliding stop.
9. Complete 3 $\frac{1}{2}$ spins to the left.
10. Hesitate to complete pattern.

AQHA Working Cow Horse

Pattern 2

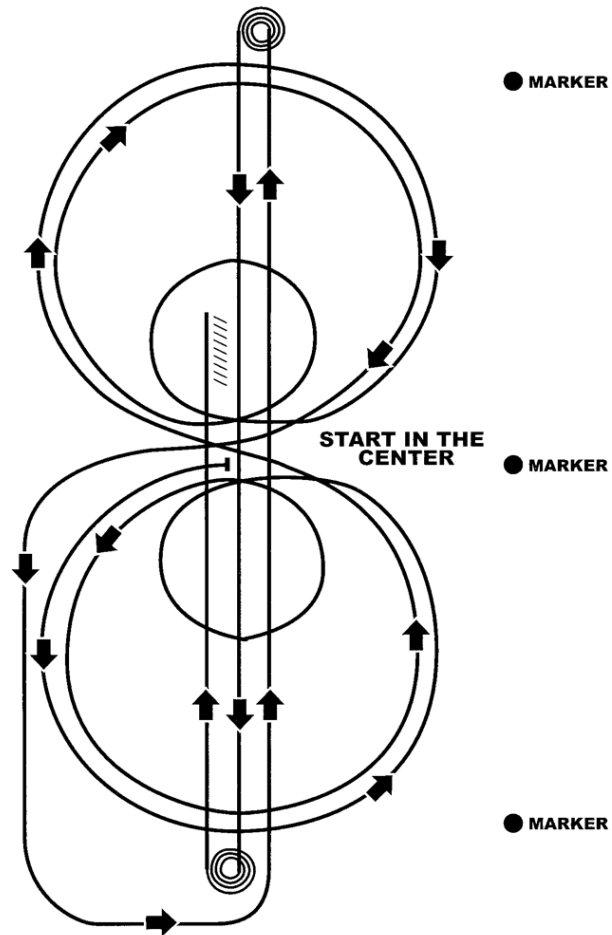

t

Mandatory Marker Along Fence or Wall

Trot to center of arena and stop. Start pattern facing toward judge.

1. Pick up left lead, complete three circles to the left. The first one large and fast, the second small and slow, the third large and fast.
2. Change leads at center of arena.
3. Complete three circles to the right. The first one large and fast, the second small and slow, the third large and fast.
4. Change leads at center of arena.
5. Do not stop, continue on to run downs.
6. Run to far end past the marker to a sliding stop. Hesitate
7. Complete 3 1/2 spins to the left. Hesitate.
8. Run to far end past the marker to a sliding stop. Hesitate
9. Complete 3 1/2 spins to the right. Hesitate.
10. Run past center marker to a sliding stop. Hesitate. Back at least 10 feet in a straight line. Hesitate
11. Hesitate to complete pattern.

AQHA Working Cow Horse

Pattern 3

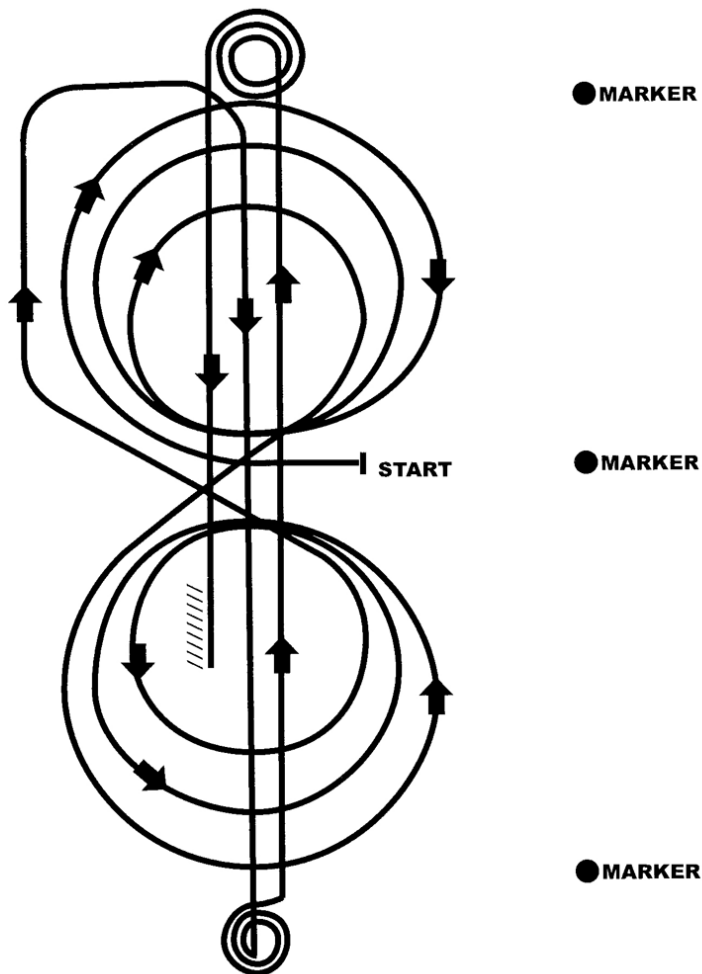

Mandatory Marker Along Fence or Wall

Trot to center of arena and stop. Start pattern facing toward judge.

1. Begin on right lead and complete three circles to right, two large fast circles followed by one small slow circle, change to left lead.
2. Complete three circles to left, two large, fast circles followed by one small slow circle. Change to right lead.
3. Continue loping around end of arena without breaking gait.
4. Run up center of arena to far end past the end marker and come to a sliding stop.
5. Complete 3 1/2 spins to the right.
6. Run up center of arena past the end marker, come to a sliding stop.
7. Complete 3 1/2 spins to the left. Run back to middle of the arena past the center marker and come to a sliding stop.
8. Back at least 10 feet in a straight line.
9. Hesitate to complete pattern.

AQHA Working Cow Horse

Pattern 4

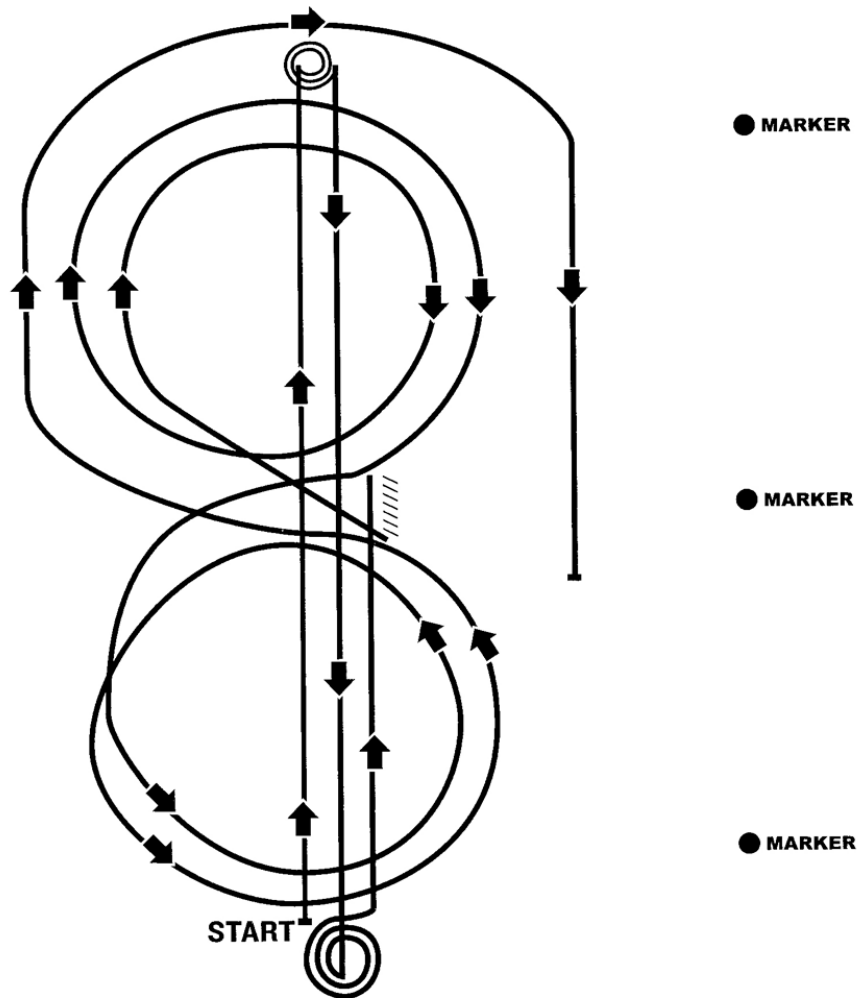

1. Start at end of arena.
2. Run up center of arena past the end marker and come to a sliding stop. Complete 3 1/2 spins to the left.
3. Run to other end of arena past the end marker and stop. Complete 3 1/2 spins to the right.
4. Run past the center marker and stop.
5. Back at least 10 feet in a straight line.
6. Complete 1/4 turn to the left, hesitate. Begin on right lead. Circle to the right. Complete two circles to the right, the first one small and slow and the second large and fast. Change leads at the center of the arena.
7. Complete one small, slow circle and one large, fast circle. Change leads to the right.
8. Run around end of arena to the other side, past the center marker, at least 20 feet from fence and come to a sliding stop.
9. Hesitate to complete pattern.

AQHA Working Cow Horse

Pattern 5

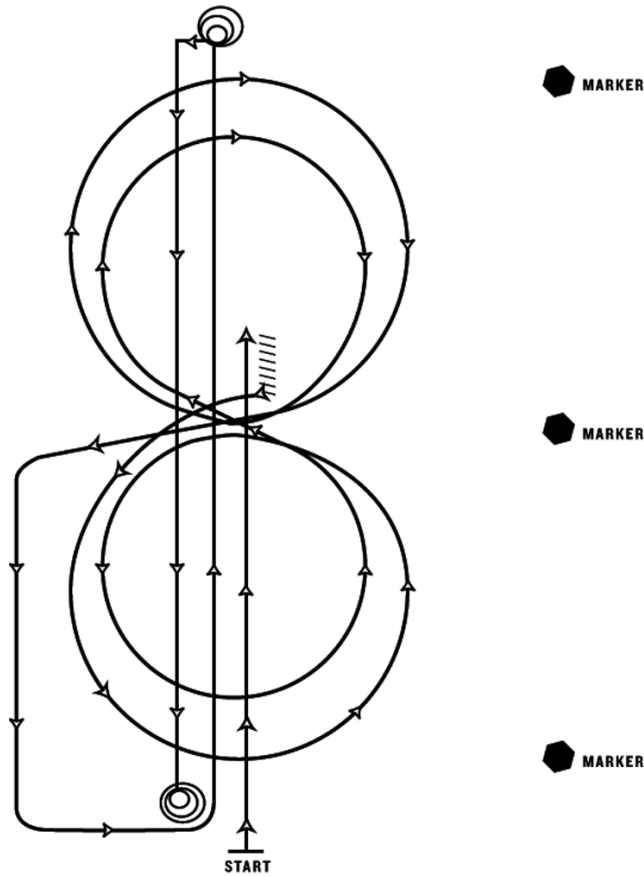

This pattern works best when the exhibitor and cattle enter from the same end of arena.

1. Start at end of arena.
2. Run past the center marker and stop.
3. Back up at least 10 feet.
4. Complete 1/4 turn to the left.
5. Complete 2 circles to the left, the first one large and fast and the second small and slow. Change leads at the center of the arena.
6. Complete two circles to the right, the first one small and slow, the second large and fast. Change leads at the center of the arena.
7. Continue around end of arena without breaking gait or changing leads, run down center of arena past end marker, come to a square sliding stop.
8. Complete 3 1/2 spins to the right.
9. Run down center of arena past end marker and come to a square sliding stop.
10. Complete 3 1/2 spins to the left.
11. Hesitate to complete pattern.

AQHA Working Cow Horse

Pattern 6

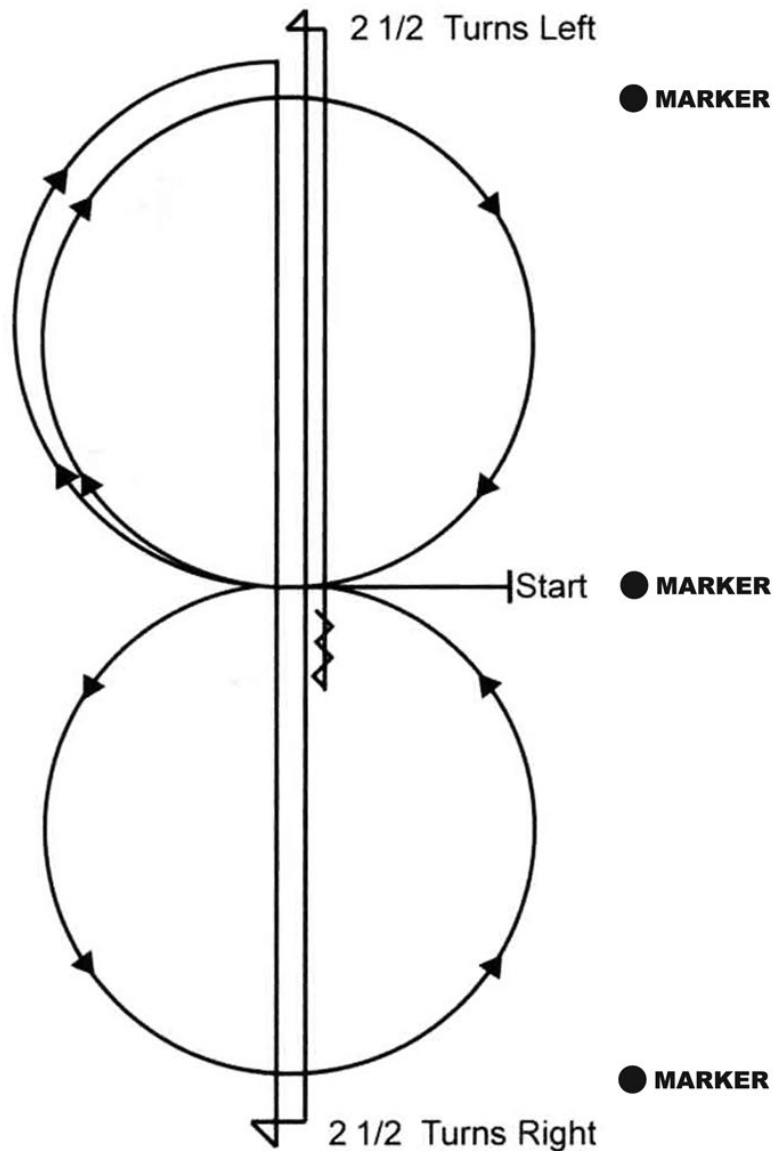

Trot to center of arena, stop. Start pattern facing towards judge

1. Beginning on the right lead lope one circle to the right. Change leads to the left.
2. Complete one circle to the left. Change leads to the right and go to the top of the arena.
3. Run down center of arena past the end marker and come to a sliding stop.
4. Complete 2 1/2 spins to the right.
5. Run to the other end of the arena, past the end marker and come to a sliding stop.
6. Complete 2 1/2 spins to the left.
7. Run past the center marker, stop, back at least 10 feet.

Hesitate to complete pattern.

AQHA Working Cow Horse

Pattern 7

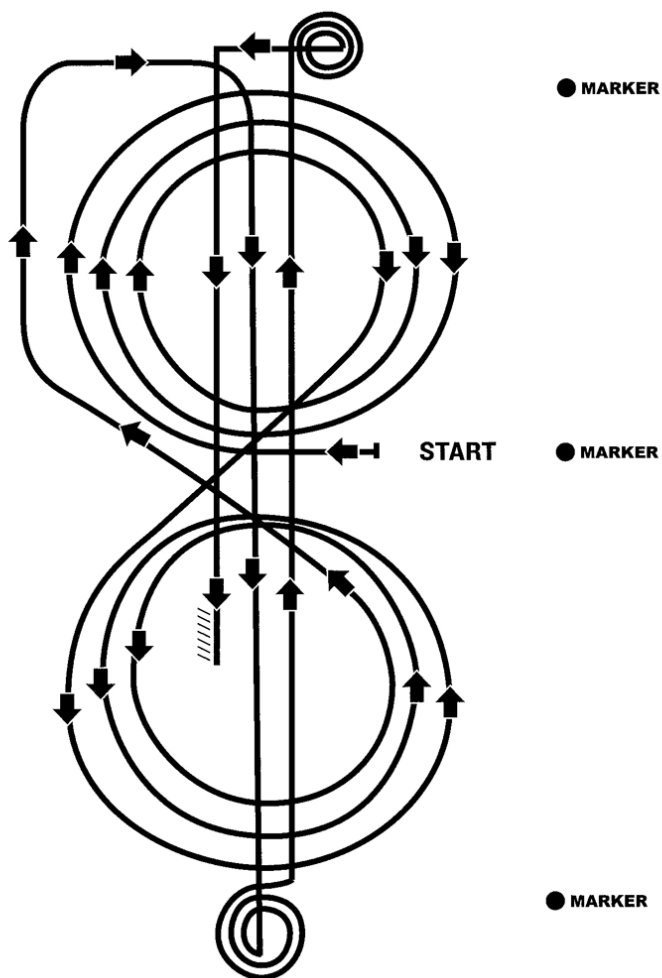

Trot to center of arena and stop. Start pattern facing toward judge.

1. Begin at center of arena. Pick up right lead and complete three circles, the first large, fast, the second small, slow, the third large, fast. Change leads to the left.
2. Complete three circles: the first large and fast; the second small and slow; the third large and fast. Change leads to the right.
3. Continue loping around end of arena without breaking gait or changing leads.
4. Run down center of arena, past end marker and come to a sliding stop. Hesitate.
5. Complete 3 1/2 spins to the right.
6. Run down center of arena past end marker and come to a sliding stop. Hesitate.
7. Complete 3 1/2 spins to the left.
8. Run past center marker and come to a sliding stop.
9. Back up at least 10 feet.
10. Hesitate to complete pattern.

AQHA Working Cow Horse

Pattern 8

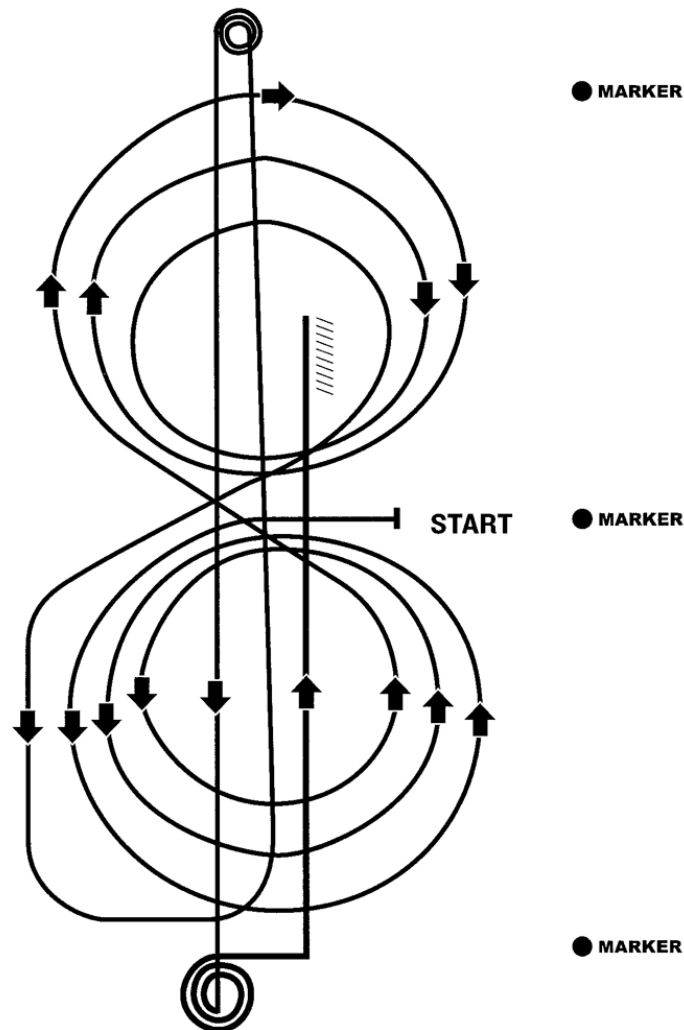

Trot to center of arena and stop. Start pattern facing toward judge.

1. Beginning on the left lead complete three circles: two big fast circles; then one small slow circle. Change leads to the right.
2. Complete three circles to the right: two large fast circles, then one small slow circle. Change leads to the left.
3. Continue around end of arena without breaking gait or changing leads, run down center of arena past end marker, come to a square sliding stop.
4. Complete 3 1/2 spins to the left.
5. Run down center of arena past end marker and come to a square sliding stop.
6. Complete 3 1/2 spins to the right.
7. Run down center of arena past center marker and come to a square sliding stop.
8. Back up at least 10 feet.
9. Hesitate to complete pattern.

AQHA Working Cow Horse

Pattern 9

3 1/2 TURNS RIGHT

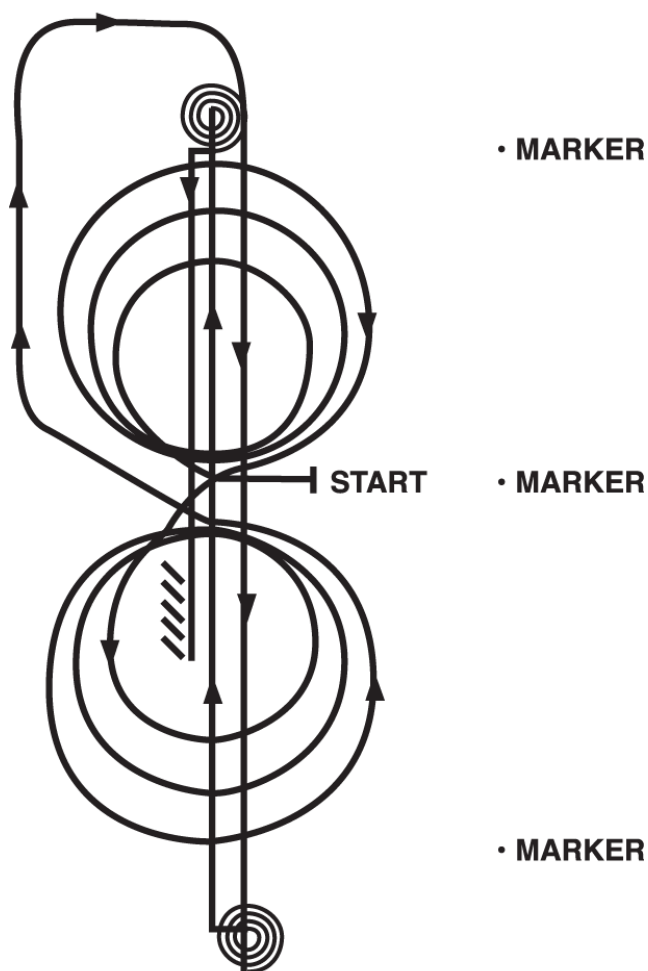

3 1/2 TURNS LEFT

Trot to center of arena, stop. Start pattern facing toward judge.

1. Beginning on the right lead complete 3 circles to the right; the first circle small and slow followed by two large fast circles. Change leads at the center of the arena.
2. Complete 3 circles to the left, the first circle small and slow followed by two large fast circles. Change leads at the center of the arena.
3. Continue around end of arena without breaking gait or changing leads, run down center of arena past end marker, and execute a square sliding stop.
4. Complete 3 1/2 spins to the left.
5. Run down center of arena past end marker, and execute a square sliding stop.
6. Complete 3 1/2 spins to the right.
7. Run down center of arena past center marker, and execute a square sliding stop.
8. Back up at least 10 feet.
9. Hesitate to complete pattern.

Working Cow Horse

Pattern 10

3 1/2 TURNS RIGHT

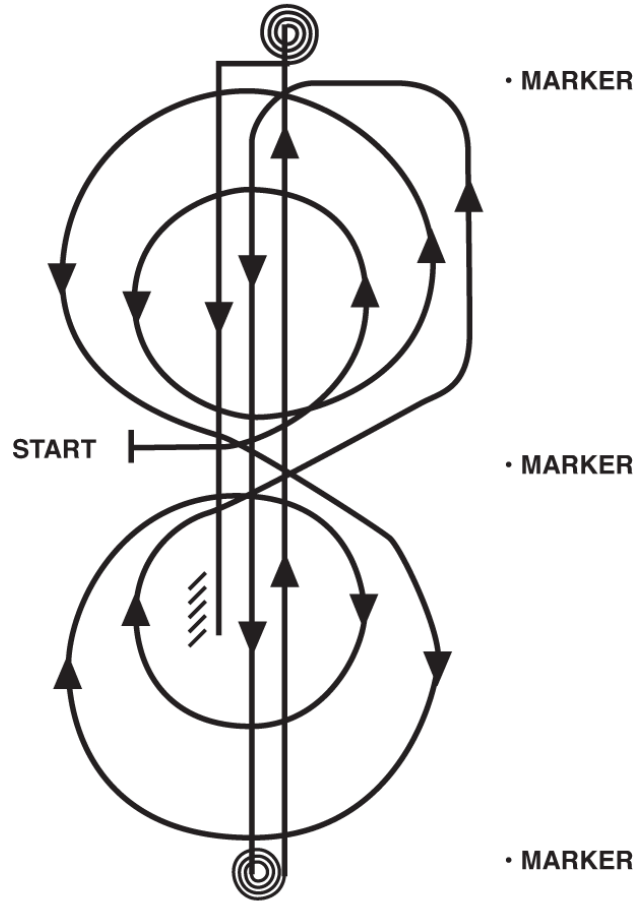

3 1/2 TURNS LEFT

Trot to center of arena, stop. Start pattern facing away from judge.

1. Beginning on the left lead, complete 2 circles to the left; the first circle small and slow, the second circle large and fast.
2. Complete 2 circles to the right; the first circle large and fast, the second circle small and slow. Change leads at the center of arena.
3. Continue around end of arena without breaking gait or changing leads, run down center of arena past end marker, and execute a square sliding stop.
4. Complete 3 1/2 spins to the left.
5. Run down center of arena past end maker, and execute a square sliding stop.
6. Complete 3 1/2 spins to the right.
7. Run down center of arena past center marker, and execute a square sliding stop.
8. Back up at least 10 feet.
9. Hesitate to complete pattern.

AQHA Working Cow Horse

Pattern 11

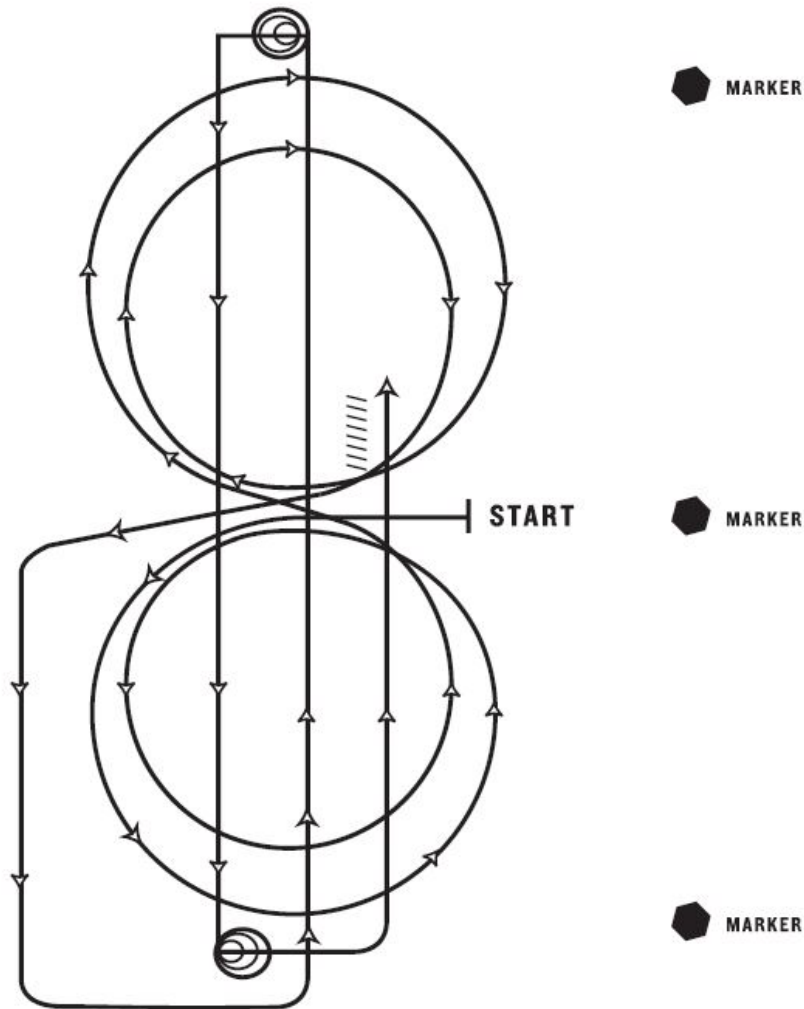

Trot to center of arena, stop. Start pattern facing towards judge

1. Beginning on the left lead, complete 2 circles to the left; the first circle large and fast, the second circle small and slow. Change leads at the center of the arena.
2. Complete 2 circles to the right; the first circle large and fast, the second circle small and slow. Change leads at the center of arena.
3. Continue around end of arena without breaking gait or changing leads, run down center of arena past end marker, and execute a square sliding stop.
4. Complete 3 1/2 spins to the left.
5. Run down center of arena past end maker, and execute a square sliding stop.
6. Complete 3 1/2 spins to the right.
7. Run down center of arena past center marker, and execute a square sliding stop.
8. Back up at least 10 feet.
9. Hesitate to complete pattern.

AQHA Working Cow Horse

Pattern 12

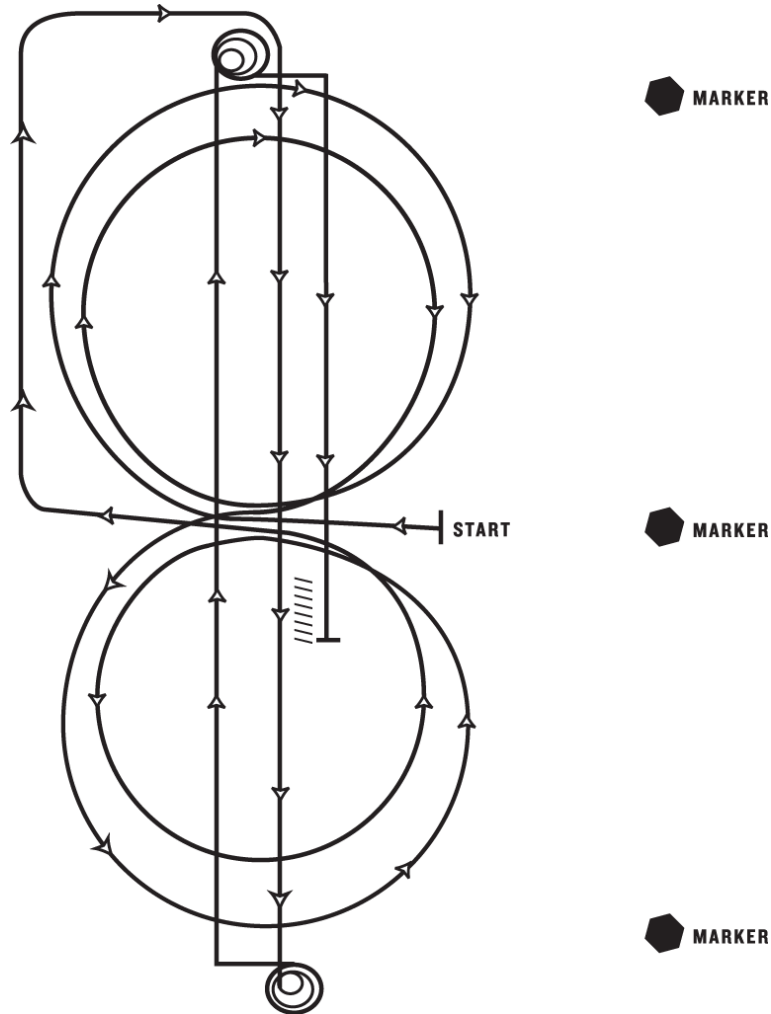

Trot to center of arena, stop. Start pattern facing toward judge.

1. Beginning on the right lead complete 2 circles to the right; the first circle large and fast and the second small and slow. Change leads at the center of the arena.
2. Complete 2 circles to the left, the first circle large and fast and the second small and slow. Change leads at the center of the arena.
3. Continue around end of arena without breaking gait or changing leads, run down center of arena past end marker, and execute a square sliding stop.
4. Complete 3 1/2 spins to the left.
5. Run down center of arena past end marker, and execute a square sliding stop.
6. Complete 3 1/2 spins to the right.
7. Run down center of arena past center marker, and execute a square sliding stop.
8. Back up at least 10 feet.
9. Hesitate to complete pattern.

TIMED EVENT DIVISION CLASSES

General Rules

1. Attire: It is the objective of the 4-H program for exhibitors to be dressed cleanly and neatly. Protective headgear may be worn in any class. ASTM/SEI approved safety helmets are strongly recommended in all speed events.
 - a. A western (cowboy) hat or protective headgear (ASTM/SEI approved safety helmets are strongly recommended), which must be on exhibitor's head when exhibitor enters arena. Exception: Show management may make use of a hat optional in speed events. If hat use is declared as optional in speed events, a five second penalty will be assessed if the hat or helmet is not on the exhibitor's person during the time the exhibitor is in the arena. Public announcement of this policy should be made prior to start of speed events.
 - b. Exhibitor number visibly worn by exhibitor or on the saddle pad.
 - c. A shirt with long sleeves, a collar (band, standup, tuxedo, etc.), and shirt tail to be tucked in pants in all classes. Variations such as short sleeves are permitted if covered with a long sleeve jacket.
 - d. Long pants.
 - e. Cowboy boots, except for special cases of handicapped individuals.
 - f. Spurs or chaps are optional.
 - g. Gloves are optional in all classes.
 - h. Ball caps, tanks tops, T-shirts or jersey-type shirts are not to be worn.
 - i. See individual division and class rules for exceptions where class specifications indicate otherwise.
 - j. Any change from the stated requirements (a – i. above) must be agreed upon by the judges and show superintendent, and announced to contestants prior to start of the class. It is the contestant's responsibility to bring questionable attire to the attention of show management prior to wearing it in any competition, as judge or official may penalize or disqualify contestants who do not conform.
2. *No exhibitor may be tied, buckled or fastened in or on any part of the saddle in any manner or by any means while on show grounds.* This includes but is not limited to string, rope, Velcro, rubber bands of any size or strength. Contestants exhibiting as such should be disqualified from the class. Safe, humane animal handling and riding practices are to be prioritized and followed at all times and all places on the show grounds.
3. Western type equipment must be used, western saddle required. The use of a mechanical hackamore or any type of bridle with a head stall is allowed; however, the judge or a designated show official may prohibit the use of bits or equipment that they considers severe. Closed reins recommended for all bridles.

Optional equipment: protective boots, leg wraps, tie-downs and nosebands (no bare metal in contact with the horse's head), running martingales in barrels, poles, stakes, and spurs not to be used forward of the cinch. Whip, crop, rope or bat; however, the judge must disqualify any contestant for excessive use of whip, rope, crop, bat or reins anywhere on the horse.

Prohibited equipment: wire chin straps, regardless of how padded or covered, chin straps narrower than one-half inch. Chain, wire, metal tie down or bonnets, regardless if they are covered.

The judge or designated show officials have the authority to require the removal or alteration of any piece of equipment which, in his/their opinion is unsafe, tends to give unfair advantage or is deemed inhumane.

4. An electric timer should be used when accessible at district and state shows. At least two stop watches should be used with the average time of the watches used by the official timer to determine the official time if an electric timer is not available.
5. In the event of a tie in a timed class, the contestant declared the winner in the runoff must run the pattern in not more than two seconds over his original time or the runoff must be held again. A flip of the coin may break ties in lieu of a runoff if unanimously agreed upon by the tied contestants.
6. The judge or a designated show official, must disqualify a contestant for excessive use of a bat, crop, or whip anywhere on the horse.
7. Any horse receiving inhumane treatment while entering, exhibiting or exiting the arena may be dismissed and disqualified upon the discretion of the judge or designated show official.
8. Judge has the authority to excuse and/or disqualify any horse deemed unsafe or out of control.
9. An exhibitor will be excused from the class (disqualified) if there is a tack or equipment breakage that the judge feels is a safety hazard.
10. The exhibitor will not be allowed a rerun if affected by equipment failure or accident to horse or rider.
11. The exhibitor will be disqualified if their horse falls (shoulder hits the ground) and/or the rider is dismounted from the horse.
12. A show official or judge shall be appointed to make decisions regarding entrants following course in speed events. Close calls should be made in favor of the exhibitor. An exhibitor is considered on course as long as deviations through the course are corrected so that the final path of the horse is on the correct side of the obstacles. The decision of the official or judge on pattern accuracy is final and not subject to review.
13. *If the use of western type hats is declared as optional by the show committee, a five (5) second penalty will be assessed if the hat or helmet is not on the exhibitor's person for the entire time the exhibitor is in the arena.*

BARREL RACE

1. See Attire, Tack and Equipment requirements in previous section on General Rules for Speed Events.
2. A closed gate start and finish will be used. For purposes of the closed start gate: A starting box (12 to 16 ' deep recommended), constructed behind the arena gate to contain the exhibitor immediately prior to exhibiting is considered part of the arena; the arena gate going from the box to the arena doesn't have to close before contestant's pattern begins. Timing shall begin as soon as the horse's nose reaches the starting line and will be stopped when the horse's nose passes over the finish line.
3. The course must be measured exactly. If the course is too large for the available space, then the pattern should be reduced five yards at a time until the pattern fits the arena.
4. Brightly colored, 55 gallon, steel drums with both ends in must be used. No rubber or plastic barrels or barrel pads shall be used at district or state shows.

5. A clearly visible starting line shall be indicated by markers on the sides of the arena. The barrel racing contest is strictly a timed event. An electric timer when accessible will be used for official time. Otherwise, at least two watches shall be used with the average time of the watches to be the official time.
6. Knocking over a barrel will result in a five second penalty.
7. At a signal from the announcer, starter or timer, such as the word "go" the contestant will go to barrel number 1 passing to the left of this barrel, complete a turn around the barrel, then on to barrel number 2, this time beginning to the right of the barrel with a turn around the barrel. At barrel number 3, begin to the right of the barrel, and complete a turn around the barrel.
8. As soon as the turn is completed around barrel 3, the contestant sprints the horse to the finish line.
9. This barrel course may also be run to the left. For example, the contestant will start to barrel number 2, beginning on the right of this barrel, then to barrel number 1, beginning on the left of the barrel, then to barrel number 3, beginning on the right of the barrel, followed by the final sprint to the finish line.
10. A show official or judge shall be appointed to make decisions regarding entrants following course in speed events. Close calls should be made in favor of the exhibitor. An exhibitor is considered on course as long as the turns are started and finished on the correct side of the barrels and that deviations through the course are corrected so that the final path of the horse is on the correct side of the obstacles. The decision of the official or judge on pattern accuracy is final and not subject to review.
11. Any horse breaking the plane of the time line before completion of the pattern is disqualified.
12. The course should allow for ample room to turn and stop. (First and second barrel need to be at least 20 feet from the fence.)

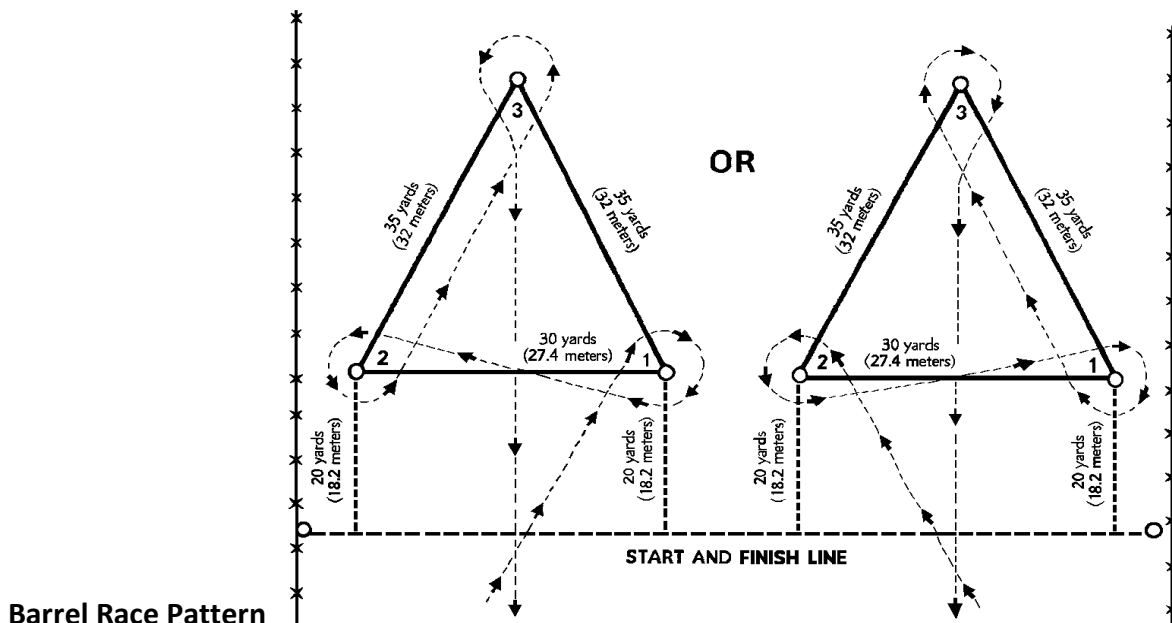

POLE BENDING

1. See Attire, Tack and Equipment requirements in previous section on General Rules for Speed Events.
2. The pole bending pattern is to be run around six poles. Each pole is to be twenty-one feet apart, and the first pole is to be twenty-one feet from the starting line. Poles shall be set on top of the ground, six feet in height, with no base more than 14 inches in diameter.
3. A horse may start either to the right or to the left of the first pole and then run the remainder of the pattern accordingly.
4. Pole bending is a timed event. An electric timer when accessible will be the official time. Otherwise, at least two watches shall be used with the average time of the watches to be the official time.
5. Knocking over a pole will result in a five second penalty. Any horse breaking the plane of the time line before completion of the pattern is disqualified.
6. A closed gate start and finish will be used. For purposes of the closed start gate: A starting box (12 to 16 ' deep recommended), constructed behind the arena gate to contain the exhibitor immediately prior to exhibiting is considered part of the arena, i.e. the arena gate going from the box to the arena doesn't have to close before contestant's pattern begins. Timing shall begin as soon as the horse's nose reaches the starting line and will be stopped when the horse's nose passes over the finish line.
7. A show official or judge shall be appointed to make decisions regarding entrants following course in speed events. Close calls should be made in favor of the exhibitor. An exhibitor is considered on course as long as the turns are started and finish on the correct side of each pole and that deviations through the course are corrected so that the final path of the horse is on the correct side of the obstacles. The decision of the official or judge on pattern accuracy is final and not subject to review.
8. A contestant may touch a pole with his or her hand.

Pole Bending Pattern

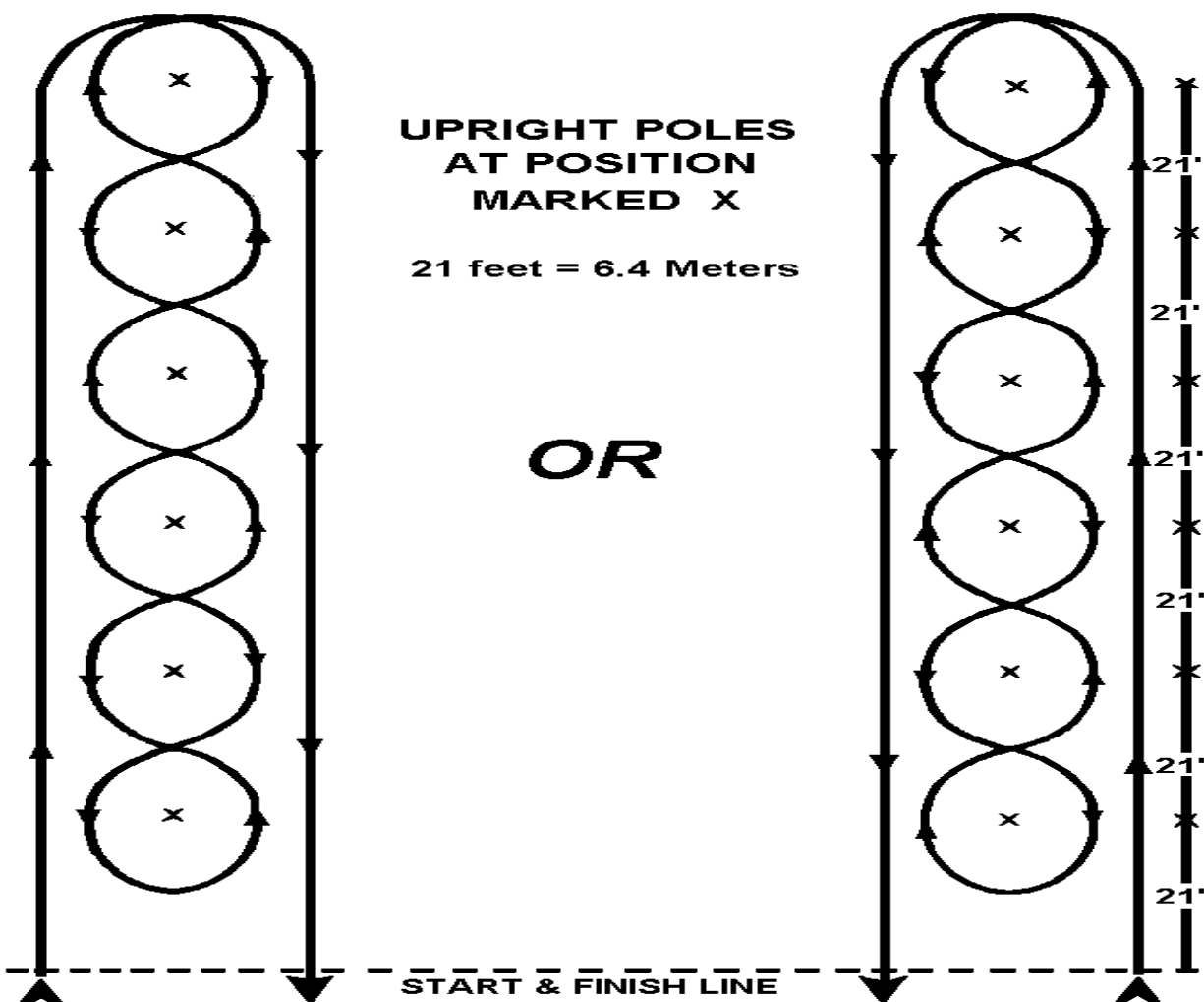

STAKES (FIGURE 8 RACE)

1. See Attire, Tack and Equipment requirements in previous section on General Rules for Speed Events.
2. The start and finish line is 20 feet wide and marked by two upright markers (10 feet on each side of the center line and short enough so as to not interfere with the electric timer if one is used.) The first and second poles (same requirements of height and base as in pole bending) marking the centerline are each 40 feet from the start and finish line, making them a total of 80 feet apart.
3. This is a timed event. Timing shall begin as soon as the horse's nose reaches the starting line and will be stopped when the horse's nose passes over the finish line.
4. A closed gate start and finish will be used. For purposes of the closed start gate: A starting box (12 to 16 ' deep recommended), if is constructed behind the arena gate to contain the exhibitor immediately prior to exhibiting is

considered part of the arena, i.e. the arena gate going from the box to the arena doesn't have to close before contestant's pattern begins. Timing shall begin as soon as the horse's nose reaches the starting line and will be stopped when the horse's nose passes over the finish line.

5. The contestant is allowed a running start and may begin his run from either the left or right side of the first pole. Start by crossing the center line between the poles, turn around the second pole, cross over the center line again between the poles, then around the first pole and run back across the finish line. The pattern calls for one left and one right turn, the order depends on which side of the 1st pole you pass to the starting line. *The center line is the imaginary line connecting the 1st and 2nd poles, not the starting and finish line between upright markers. Passing by the 1st pole to start such that the pole is on your right would place your 1st turn to begin to the left of the 2nd pole. Your second turn would begin to the right of the 1st pole. Conversely, approaching the start line to the left side of the 1st pole would make the first turn to begin to the right side of the 2nd pole.*
6. A show official or judge shall be appointed to make decisions regarding entrants following course in speed events. Close calls should be made in favor of the exhibitor. An exhibitor is considered on course as long as the turns are started and finish on the correct side of the pole and that deviations through the course are corrected so that the final path of the horse is on the correct side of the obstacles. The decision of the official or judge on pattern accuracy is final and not subject to review.
7. Failing to cross over the center line and between the markers before the first turn, or failing to cross over the center line and between the markers between the first and second turns will result in no time.
8. The contestant may touch a pole. Knocking over a pole or marker is a disqualification.
9. Failure of a contestant to cross the start and finish line between the markers shall result in no time.

Stake Race (Figure 8) Pattern

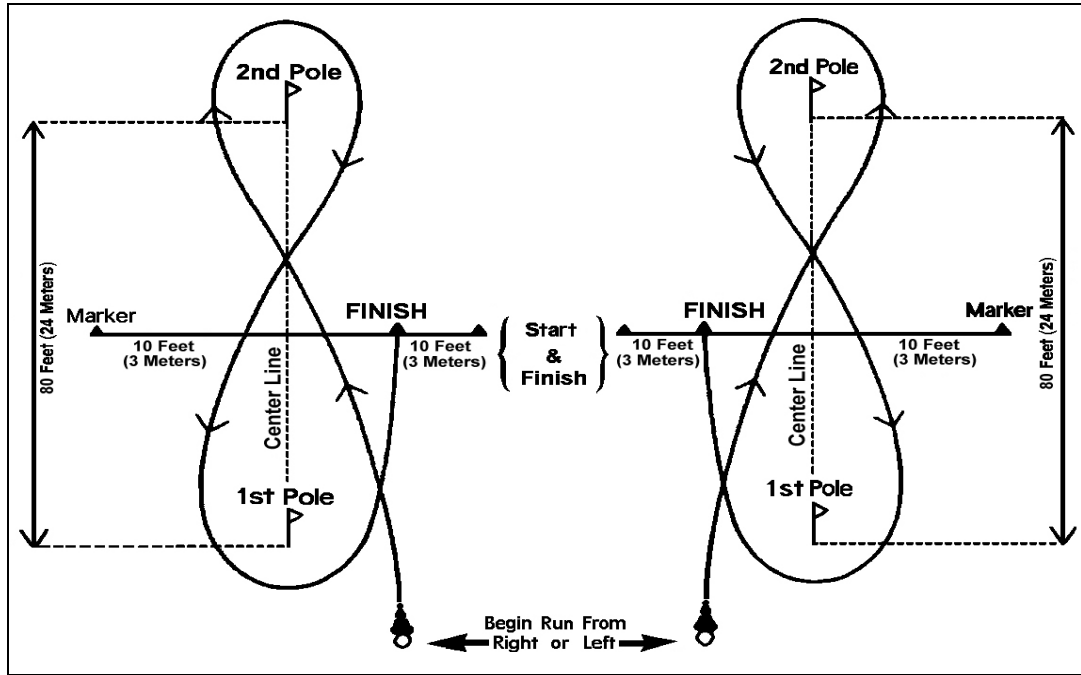

Pattern Below is Not Correct (Horse doesn't pass across center line between poles before making the first turn).

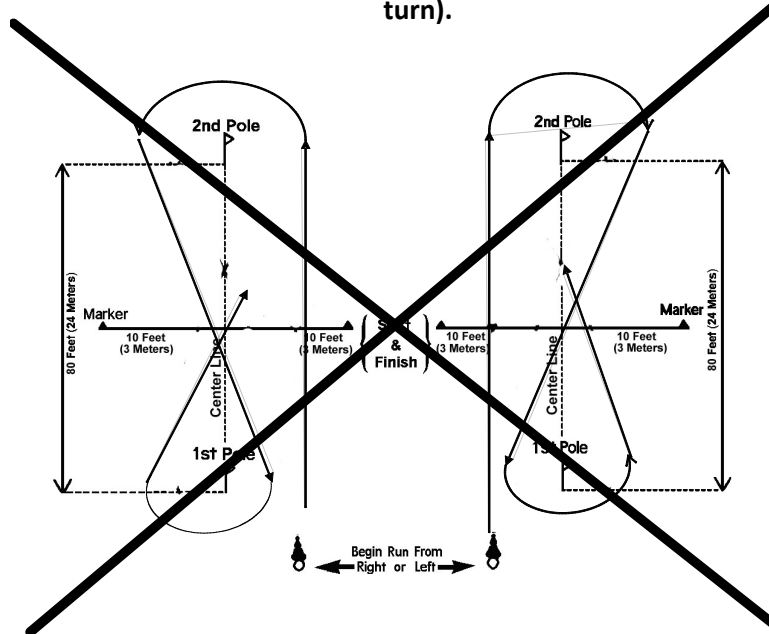

Flag Race

1. See Attire, Tack and Equipment requirements in previous section on General Rules for Speed Events.
2. The course (see Barrel Race fig.) is set up in the same manner as for the Cloverleaf Barrel Race. Two 5-gallon buckets filled with approximately 4 inches of sand should be placed on the centers of the 1st and 3rd barrels. It is recommended that Flag Race follows completion of the Barrel Race classes.
3. The course must be measured exactly. If the course is too large for the available space, then the pattern should be reduced five yards at a time until the pattern fits the arena.
4. Brightly colored, 55 gallon, steel drums with both ends in must be used. No rubber or plastic barrels or barrel pads shall be used at district or state shows.
5. A clearly visible starting line shall be indicated by markers on the sides of the arena. The barrel racing contest is strictly a timed event. An electric timer when accessible will be used for official time. Otherwise, at least two watches shall be used with the average time of the watches to be the official time.
6. Flag to be picked up at first barrel, exhibitor to proceed around the second barrel and deposit flag in container in third barrel and then cross finish line. Rider may run the course to right or left.
7. Containers for flags shall be at least the size of a 2-gallon bucket. Plastic or rubber containers are recommended. Material in containers should be suitable material to allow flag to be easily removed and stuck, e.g., soybeans, corn, wheat or loose sand. Flagsticks should be 18" in length with recommended 3/8" or larger round dowel, with blunt ends. Flags must be attached with fabric measuring at least 5" x 7". Buckets should be placed in the center of the 1st and 3rd barrels.
8. Disqualification results by the rider dropping the flag, failing to pick up the flag on the first pass, flag not staying in the "stuck position" in the material inside the container on the third barrel, dropping the flag into the bucket with the flag end down, not going around the second barrel, knocking over any flag container, or knocking over first or third barrel, or using the flag as a bat.
9. Knockdown of the free-standing barrel (second barrel) is a 5-second penalty.
10. A closed gate start and finish will be used. For purposes of the closed start gate: A starting box (12 to 16 ' deep recommended), if is constructed behind the arena gate to contain the exhibitor immediately prior to exhibiting is considered part of the arena, i.e. the arena gate going from the box to the arena doesn't have to close before contestant's pattern begins. Timing shall begin as soon as the horse's nose reaches the starting line and will be stopped when the horse's nose passes over the finish line.

HUNTER CLASSES

General Rules

1. General Rules.

a. Attire

- i. Hunt coats of traditional hunt seat style and colors such as navy, dark green, grey, black or brown. Maroon and red are improper.
- ii. Breeches or jodphurs of traditional shades of buff, khaki, canary, light gray, or rust.
- iii. High English boots or paddock (jodphur) boots of black or brown.
- iv. Safety helmet of traditional colors (black, navy blue or brown). ASTM/SEI approved safety helmets are strongly recommended. Exhibitors must wear properly fastened protective headgear that meets ASTM/SEI standards or equivalent international standards for equestrian use when schooling or exhibiting over fences while on the show grounds.
- v. Hair must be neat and contained (as in a net or braid).
- vi. Correct exhibitor number must be visibly displayed on exhibitor or on saddle pad.
- vii. Gloves, spurs (**unrowelled** type that are blunt, round or include a smooth rolling ball) and crops or bats are optional. Exception: Spurs, crops or bats are not allowed in halter or showmanship classes.
- viii. Braiding of mane or tail in hunt style optional in all classes.
- ix. Any changes from the stated requirements (i - viii above) must be agreed upon by the judges and show superintendent, and announced to contestants prior to class. It is the contestant's responsibility to bring questionable attire to the attention of show management prior to wearing it in any competition, as judge or official may penalize or disqualify contestants who do not conform.

b. Equipment.

- i. In all hunt classes, an English snaffle (no shank), kimberwick, Pelham and/or full bridle (with two reins), all cavesson nosebands and plain leather brow bands must be used.
- ii. Bits of any style (pelham, snaffle, kimberwick) featuring mouthpieces with cathedrals, donuts, prongs, edges or rough, sharp material shall be cause for elimination. Square stock, polo mouthpieces and mouthpieces with wrapped metal are prohibited. If a curb bit is used, the chain must be at least 1/2" in width and flat against the jaw of the horse. Wire chin straps, regardless of how padded or covered are prohibited.
- iii. In reference to bit mouthpieces, nothing may protrude below the mouthpiece (bar). Broken or solid mouthpieces must be between 5/16" to 3/4" in diameter, measured 1" from the cheek and may have a port no higher than 1 1/2". They may be inlaid, synthetic wrapped, including rubber or plastic or incased. On broken mouthpieces only, connecting rings of 1 1/4" or less in diameter or connecting flat bar of 3/8" to 3/4" (measured top to bottom with a maximum length of 2") and which lie flat in the horse's mouth are acceptable. Snaffle bit rings may be no larger than 4 inches in diameter. Any bit having a fixed rein

requires use of a curb chain. Smooth round, slow twist, corkscrew, single twisted wire, double twisted wire mouthpieces and straight bar or solid mouthpieces are allowed.

- iv. Saddles must be black and/or brown colors and have the hunting or forward seat type, and may have a knee insert on skirt. Saddle pads should be white or natural color with no ornamentation, and fit size and shape of saddle, except when necessary to accommodate numbers on both sides, for which a square pad or suitable attachment may be used.
- v. Optional equipment. Unrowelled spurs (blunt, round or include a smooth rolling ball), crops or bats, gloves, English breast plate, braiding of mane and/or tail in hunt style, rubber reins and unrowelled slip on spurs. Protective boots, leg wraps and bandages are optional only in Hunt Seat Equitation.
- vi. Prohibited equipment: draw reins, rowelled spurs, standing or running martingales, figure 8 or flash cavessons. Protective boots, leg wraps and bandages optional in hunt seat equitation only, not allowed in hunter under saddle or hunter hack. Exception: allowed at discretion of judge for use outdoors during inclement weather in hunter hack.
- vii. *No exhibitor may be tied, buckled or fastened in or on any part of the saddle in any manner or by any means while on show grounds.* This includes but is not limited to string, rope, Velcro, rubber bands of any size or strength. Contestants exhibiting as such should be disqualified from the class.

HUNTER UNDER SADDLE

1. General Rules

- a. See attire and tack requirements in previous section covering General Rules for Hunter Classes.
- b. The purpose of the hunter under saddle horse is to present or exhibit a horse with a bright, alert expression, whose gaits show potential of being a working hunter. Therefore its gait must be free-flowing, ground covering and athletic. Hunters under saddle should be suitable to purpose. Hunters should move with long, low strides reaching forward with ease and smoothness, be able to lengthen stride and cover ground with relaxed, free-flowing movement, while exhibiting correct gaits that are of the proper cadence. The quality of movement and the consistency of the gaits are major considerations. Horses should be obedient, have a bright expression with alert ears, and should respond willingly to the rider with light leg and hand contact. Horses should be responsive and smooth in transition. When asked to extend the trot, or hand gallop, they should move out with the same flowing motion. The poll should be level with, or slightly above, the withers to allow proper impulsion behind. The head position should be slightly in front of, or on the vertical.

2. Class Procedures

- a. Horses are to show on the flat at walk, trot and canter while maintaining light contact with the horse's mouth. Maximum credit shall be given to the flowing, balanced, willing horse. Large numbers in this class will necessitate elimination heats to accommodate all horses. The suggested maximum number is 25 horses in each heat.
- b. Horses must work both ways of the ring at all gaits to demonstrate their ability with different leads. Horses may be required to go from any gait to any other gait or extend any gait at the discretion of the judge. Horses will reverse by turning toward the inside of the arena.

- c. The judge may ask finalists to hand gallop, but never more than eight horses to gallop at one time.
- d. All or only horses in finals may be required to back.
- e. Any portion of a class or heat may be placed on the rail for extra work by the judge at any time.
- f. Entries shall be penalized for being on wrong lead, or wrong diagonal at the trot; quick, short, or vertical stride; excessive speed; excessive slowness; failure to take the appropriate gait when called for; head carriage too high or low; over flexing or excessive nosing out; stumbling, failure to maintain light contact on the horse's mouth; breaking gait; tossing of head; consistently showing too far off the rail.
- g. Judge has the authority to excuse and/or disqualify any horse deemed unsafe or out of control. Fall of horse and/or rider falling off results in disqualification. An exhibitor will be excused from the class (disqualified) if there is a tack or equipment breakage that the judge feels is a safety hazard.

HUNT SEAT EQUITATION

1. General Rules.
 - a. See attire and tack requirements in previous section covering General Rules for Hunter Classes.
 - b. The purpose is to evaluate the ability of the hunter rider to perform various maneuvers on his/her horse which provides a base for natural progression to over fence classes. The hunt seat equitation on the flat is an evaluation based on the ability of a rider to perform various maneuvers in the harmony with his/her horse. The communication between horse and rider through subtle cues and aids should not be obvious. Equitation is judged on the rider and his/her effect on the horse. Hunt seat equitation on the flat provides a base for a natural progression to over fence classes. The poll should be level with, or slightly above the withers, to allow proper impulsion behind. The head should not be carried behind the vertical, giving the appearance of intimidation, or be excessively nosed out, giving a resistant appearance.
 - c. It is mandatory that the judge post the pattern at least one hour prior to commencement of the class. The pattern should be designed so the majority of exhibitors can perform it in a reasonable length of time (under 60 seconds). All patterns must include a walk, trot, canter and back. Patterns used in classes for Juniors should be restricted to maneuvers listed from Group 1. Horses' gaits are to be ridden with the same cadence and speed as you would find in the rail phase. All ties will be broken at the discretion of the judge. *Failure to complete the pattern will not be a disqualification, but shall be scored accordingly.*
2. Class Procedure.
 - a. Exhibitors may be worked individually from the gate or they may enter the arena as a group. A working order must be drawn when working individually from the gate. The entire class, or only the finalists must work at all three gaits at least one direction of the arena. Rail work can be used to break ties and possibly adjust placings. Judges should not ask the exhibitors to mount or dismount. Individual work may be compromised of any of the following:

Group #1

Walk, sitting trot, extended trot, posting trot, canter, circles, figure 8, halt, back, sidepass, address reins, demonstrate change of diagonal.

Group #2

Serpentine (trot or canter), turn on haunches or forehand, leg yield, flying or simple change of lead.

A turn on the forehand to the right is accomplished by moving haunches to the left. A forehand turn to the left is accomplished by moving haunches to the right.

When performing a leg yield, the horse should move forward and lateral in a diagonal direction with the horse's body straight with a slight flexion of the head in the opposite direction of lateral movement. When a horse yields to the right the head is slightly (just to see the eye of the horse) to the left. A horse yielding to the left is slightly flexed to the right.

Group #3

Canter and hand gallop in a straight or curved line, counter canter figure 8, drop or pick-up irons without stopping.

If riders are asked to drop their irons, they can leave them down or cross them over the withers.

3. Basic Position.

- a. Hands should be over and in front of horse's withers, knuckles 30 degrees inside the vertical, hands slightly apart and making a straight line from the horse's mouth to rider's elbow. Method of holding reins is optional, and bight of reins may fall on either side. However, all reins must be picked up at the same time.
- b. The eyes should be up and shoulders back. Toes should be at an angle best suited to rider's conformation; heels down, calf of leg in contact with horse. Iron should be on the ball of the foot and must not be tied to the girth.
- c. The Walk: Should be a four-beat gait with the rider in a vertical position with a following hand.
- d. The Posting Trot: Figure 8 at trot, demonstrating change of diagonals. At left diagonal, rider should be sitting the saddle when left front leg is on the ground; at right diagonal rider should be sitting the saddle when right front leg is on the ground; when circling clockwise at a trot, rider should be on the left diagonal; when circling counter-clockwise, rider should be on right diagonal. The rider should close his/her hip angle to allow his/her torso to follow the horizontal motion of the horse. The upper body should be inclined about 20 degrees in front of the vertical.
- e. Sitting Trot and Canter: At the sitting trot the upper body is only slightly in front of the vertical. At the canter the body should be positioned slightly more in front of the vertical. As the stride is shortened, the body should be in a slightly more erect position.
- f. Two Point Position: The pelvis should be forward, but relaxed, lifting the rider's weight off the horse's back and transferring the contact between horse and rider are the rider's legs. Hands should be forward, up the neck, not resting on the neck.
- g. Hand Gallop: A three-beat, lengthened canter ridden in two-point position. The legs are on the horse's sides while the seat is held out of the saddle. When at the hand gallop, the rider's angulation will vary somewhat as the horse's stride is shortened and lengthened. A good standard at a normal hand gallop should be about 30 degrees in front of the vertical.

4. Scoring. Exhibitors are to be scored from 0 to infinity, 70 denoting an average performance. Patterns will be divided into maneuvers and each maneuver will be scored from +3 to -3 with ½ point increments allowed.

SCORING SYSTEM: Exhibitors are to be scored from 0 to 100. Run content scores will be indicated as follows:

+ 3 = Excellent

+2 = Very good

- +1 – Good
- 0 = Correct
- 1 = Poor
- 2 = Very Poor
- 3 = Extremely Poor

Rider Form and Effectiveness – E = Excellent (5), VG = Very good (4), G = Good (2-3), A = Average (0-1)

5. Penalties. Maneuver evaluations and penalty applications are to be determined independently. The following penalties will be applied for each occurrence and will be deducted from the final score.

a. Three (3) points

- Break of gait at walk or trot up to 2 strides
- Over/under turn of $\frac{1}{8}$ to $\frac{1}{4}$
- Tick or hit of cone
- Missing diagonal up to 2 strides in the pattern or on the rail
- Obviously looking down to check leads or diagonals

b. Five (5) points

- Incorrect lead or break of gait (except when correcting an incorrect lead at the canter)
- Not performing the specified gait or not stopping when called for in the pattern within 10 feet of designated area
- Incorrect gait or break of gait at walk or trot for more than 2 strides
- Complete loss of contact between rider's hand and the horse's mouth
- Loss of iron
- Missing a diagonal more than 2 strides
- Head carried too low and/or clearly behind the vertical while the horse is in motion, showing the appearance of intimidation

c. Ten (10) points) include:

- Loss of rein
- Touching horse
- Grabbing any part of the saddle
- Cropping or spurring in front of the shoulder
- Kicking at other horses, exhibitors or judge
- Severe disobedience or resistance by horse including, but not limited to, rearing, bucking or pawing.

d. Off Pattern (OP) Exhibitors going off pattern must always place below exhibitors not incurring a disqualifying fault. Judge shall include OP in the penalty box for each occurrence. The judge shall place exhibitors with one (1) OP above an exhibitor with two (2) OP s regardless of the score.

- *Omission or addition of maneuvers*
- *Turning the wrong way*
- *Knocking over a cone or working on the wrong side of the cones*
- *Overturning more than $\frac{1}{4}$ of prescribed turn*
- *Exhibitor's going off pattern*
- *Never performing specified gait, lead or diagonal where called for*

e. Disqualifications include: (should not be placed)

- Failure by exhibitor to wear correct number in visible manner.
- Willful abuse, inhumane treatment.

- Excessive schooling or training.
- Fall by horse or rider.
- Illegal use of hands on reins.
- Use of prohibited equipment.
- Judge has the authority to excuse and/or disqualify any horse deemed unsafe or out of control

An exhibitor will be excused from the class (disqualified) if there is a tack or equipment breakage that the judge feels is a safety hazard.

HUNTER HACK

1. Judging Requirements.
 - a. See attire, bit and tack requirements in previous section covering General Rules for Hunter Classes. Exhibitors must wear properly fastened protective headgear that meets ASTM/SEI standards or equivalent international standards for equestrian use when schooling or exhibiting over fences while on the show grounds.
 - b. The purpose of hunter hack is to give horses and opportunity to show their expertise over low fences and on the flat. The hunter hack horse should move in the same style as a working hunter. The class will be judged on style over fences, even hunting pace, flat work, manners and way of going. The poll should be level with, or slightly above the withers, to allow proper impulsion behind. The head should not be carried behind the vertical, giving the appearance of intimidation, or be excessively nosed out, giving a resistant appearance. Horses are first required to jump two fences consisting of two X's or cross rails such that the lowest part of the x is 18 inches in height. Jumps do not have to be set on a line. However, if the jumps are set on a line they must be set 36, 48 or 60 feet apart, or in increments of 12 feet, but no less than 36 feet. Trotting jumps will not be penalized. PVC poles used as rails are not permitted. Horses being considered for an award then to be shown at a walk, trot and canter both ways of the show ring with light contact. A schooling area with at least one practice jump must be provided, otherwise practice time in the arena must be allowed. Horse should not be allowed practice time in the arena if a schooling area with practice jumps is provided. Exhibitors must wear properly fastened protective headgear that meets ASTM/SEI standards or equivalent international standards for equestrian use.
 - c. At the discretion of the judge, the contestants may be asked to hand gallop, pull up and stand quietly, or pull up and back following the last fence.
 - d. The class will be judged on flat work, manners, way of going, style over fences, even hunting pace and equitation of the rider. When necessary to split large classes by running more than one go-round, finalists must re-jump and rework on the flat. Placing for the class shall be determined by allowing a minimum of 70% for individual fence work and a maximum of 30% for work on the flat.
 - e. Disobediences (faults) over fences include refusals, run-outs, loss of forward movement, and unnecessary circling on course.
2. Scoring.
 - a. Horses shall be credited with maintaining an even hunting pace that covers the course with free-flowing strides. Preference is given to horses with correct jumping style that meet fences square, jumping at the center of the fence. Unsafe jumping and bad form over fences, including twisting, shall be penalized whether the fence was touched or untouched. Incorrect leads around the ends of the course and cross cantering shall be penalized, as well as excessive use of a crop. Fences in a line should be taken in the correct number of strides or be penalized.

Any error that endangers the horse and or its rider, particularly refusals or knockdowns, shall be heavily penalized.

- b. Scoring over fences shall be as in working hunter with an approximate breakdown of scoring 0-100 as follows:
- | | |
|--------|---|
| 90-100 | An excellent performer and good mover that jumps the fences with cadence, balance and style. |
| 80-89 | A good performer that jumps well or an excellent performer that commits one or two minor faults. |
| 70-79 | The average, fair mover that makes no serious faults, but lacks the style, cadence and good balance of the scoper horses or the good performer that makes a few minor faults. |
| 60-69 | Poor movers that make minor mistakes or fair to average movers that have one or two poor fences, but no major faults or disobediences. |
| 50-59 | A horse that commits one major fault, such as a hind knockdown, refusal, trot, cross canter or drops a leg. |
| 30-49 | A horse that commits two or more major faults, including front knockdowns and refusal, or jumps in a manner that otherwise endangers the horse and/or rider. |
| 10-29 | A horse that avoids elimination, but jumps in such an unsafe and dangerous manner as to preclude a higher score. |
- c. Horses eliminated in over fence portion of the class shall be disqualified. Elimination includes:
- A total of three disobediences, which can include refusal, stop, run out or extra circle.
 - Jumping an obstacle before it is reset.
 - Rider and/or horse leaving the arena before finishing.
 - Off course.
 - Holding on to the saddle with either hand will result in a disqualification.
 - Judge has the authority to excuse and/or disqualify any horse deemed unsafe or out of control.
 - Fall of horse or rider results in disqualification.
 - An exhibitor will be excused from the class (disqualified) if there is a tack or equipment breakage that the judge feels is a safety hazard.
- d. Faults to be scored accordingly during the rail include being on wrong lead, and/wrong diagonal at the trot, excessive speed or slowness at any gait, break of gait, failure to take gait, head carriage too low or high, nosing out or flexing behind the vertical, opening mouth excessively or stumbling.

Special Clovers Equestrian

To be eligible to participate at district and state 4-H qualifying horse shows, youth must be an Oklahoma 4-H member and meet the requirements, including those for enrollment, participation and minimum and maximum age as defined in the Oklahoma 4-H Membership Policy, September 1, 2024-August 31, 2025. Included in the 4-H membership policies are requirements that youth must be a member for 30 days prior to participating in contests beyond county level. For district and state qualifying horse shows, youth must be a member a minimum of 30 days prior to the show **and** a member at time that entry is due. Entry deadline may cause minimum time of membership to be increased beyond 30 days prior to the district show. For youth of minimum age, this requires youth to be 8 years of age and in the 3rd grade and a member of Oklahoma 4-H 30 days prior to the show **and** at time entry is due. This rule applies for district and state qualifying horse shows: County and state fairs, other 4-H sponsored activities, and special events may have different participation requirements.

The therapeutic riding division is intended for exhibitors with disabilities who are unable to participate in other divisions with *or* without reasonable accommodations. Exhibitors, their parent/guardian and health care professionals should determine if the classes in this division are most appropriate for their abilities *or* if they wish to participate in other divisions. If the exhibitor wishes to participate in *other* divisions, please contact your county educator as noted below if accommodations are requested. Exhibitors with disabilities may participate in *either* the Special Clovers *or* in other divisions but *not* in *both* divisions in the current year with the exception of halter classes.

Exhibitors in the Special Clovers division may participate in the following classes: Obstacle Trail, Walk-Trot Equitation, and Showmanship.

Oklahoma State University encourages persons with disabilities to participate in its programs and activities. If you anticipate needing any type of accommodation or have questions about the physical access provided, please contact your county extension educator in advance of your participation or visit. Requests for accommodations should be made to the county extension educator at least three weeks in advance of the event.

Classes included in this division are divided into two subdivisions: assisted and independent. Parent or guardian is responsible to consult with their child's health care professional to determine the appropriate level of assistance. Riders should be placed in the class that is most appropriate for their ability.

Independent – Riders in this division are able to independently control their horse safely without an assistant. Each rider will have one assistant available located within the designated area in the arena.

Assisted – Riders in this division require one or more assistants as leaders or side walkers.

General rules: Riders in the Special Clover division may not compete in any other classes with the exception of (list the halter class numbers).

Riders in this division are not required to own or lease their own horse, and their project animal may be shared, but not by more than 2 riders within the class. The project *horse* is eligible to compete within non-Special Clover divisions, following OK 4-H Horse Project guidelines for ownership eligibility.

Riders will not be attached to the horse or saddle in any manner.

Youth may not participate if they have any contraindications for participating in OK 4-H horse activities. The parent or guardian is responsible for consulting their child's health care professional(s) to determine if there are contraindications for horse activities.

A parent or guardian must be present during the horse show.

All riders will have one assistant or aide that is 14 year or older that is familiar with them and the project horse. No more than 3 aides will assist a rider in any class. Aides may communicate instruction, but physical assistance in guiding the horse will be penalized accordingly.

Tack and Attire

Either western or English equipment tack and attire can be used. Reasonable accommodations for attire can be made. Exceptions to boots (soft soled shoes, sneakers) can only be made with written permission by a medical professional.

Adaptive equipment may be used, but the rider must not be attached to the horse or saddle.

Assistants must wear long sleeve shirts and boots while in the arena.

Bridles must be worn by the horse but a halter can be placed over the bridle.

Reins may be closed or tied.

The use of a ASTM/SEI certified helmet is *required*. Helmets should be replaced every 5 years.

Optional Classes:

Obstacle Trail.

Show management will have two options for trail courses, one to use one of three patterns provided within the rulebook for Special Clovers Equestrians, or two – to develop their own trail course that will demonstrate proper horse handling techniques and skills for riders with disabilities. Management and course designers should consider the skill level of the majority of the exhibitors. All courses are to be constructed with the safety of the exhibitor in mind.

Required obstacles

A minimum of five and maximum of seven obstacles will be used.

Riders will be asked to trot or jog within the pattern.

Suggested obstacles

1. 20-36 feet between obstacles, from the end of one obstacle to the beginning of the next obstacle.
2. Figure 8 around two markers (minimum of 14 feet apart).
3. Walk-overs – at least four poles (10' in length min.) placed a minimum of 24" apart.
4. Zig-zag – Horses will be guided through a Z pattern at a walk; poles a minimum of 6' apart.
5. Serpentine of obstacles (5 obstacles used) a minimum of 10' apart.
6. 360 Box – horse would enter and turn in the box, a minimum of 10' square.
7. Stop and back.

Obstacle trail will be judged under the same rules as Ranch Trail.

Walk Trot Horsemanship/Equitation

This class will be judged on the position of the rider, balance, use of aids and ability to control the horse. Emphasis will be placed on the rider's ability to safely and independently control the horse. Aids and assistants are there to provide safety, and unnecessary assistance will be penalized by the judge.

Assistance entries must be accompanied by at least one and not more than three assistants. If one is used, they must remain in close proximity to the horse.

Assistants for independent riders must remain in the designated area during the rider's course.

Pattern requirements.

Riders will be asked to circle, halt and reverse at the walk. The trot will be performed in a straight line, a safe distance off the rail.

Showmanship: Suggested patterns.

EQUESTRIANS WITH DISABILITIES SHOWMANSHIP (WALK ONLY)

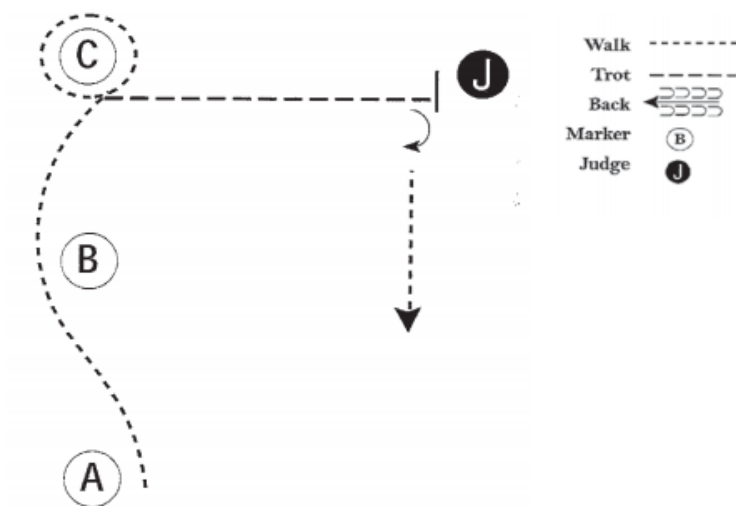

Be ready at A.

1. When acknowledged, walk from A, around B to C.
 2. Walk a tight circle around C.
 3. Walk to judge.
 4. Stop and set up for inspection.
 5. When dismissed, perform a 90 degree turn and walk away from judge. Follow the directions of your ring steward.
-

**EQUESTRIANS WITH DISABILITIES
SHOWMANSHIP (WALK-TROT)**

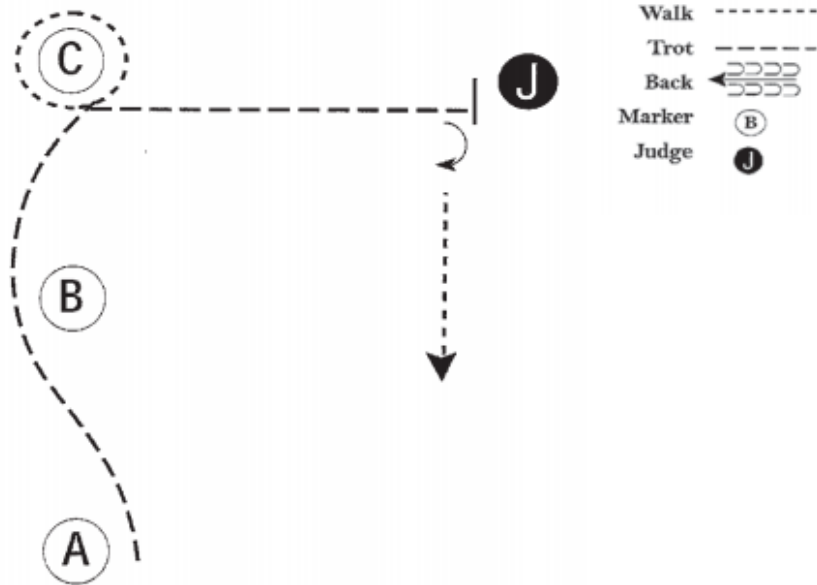

Be ready at A.

1. When acknowledged, trot from A, around B to C.
 2. Walk a tight circle around C.
 3. Trot to judge.
 4. Stop and set up for inspection.
 5. When dismissed, perform a 90 degree turn and walk away from judge.
- Follow the directions of your steward.
-

* * * * *

THE END OF DISTRICT AND STATE

QUALIFICATION HORSE SHOW RULES

* * * * *

Other 4-H Horsemanship Project Activities and Events

OKLAHOMA 4-H 2-YEAR-OLD HORSE TRAINING PROJECT CLASS

GENERAL INFORMATION, RULES AND REGULATIONS AND ENTRY FORM

Purpose:

This program provides an incentive activity for experienced 4-Hers who have developed an ability to train young horses. The objective is to encourage Oklahoma 4-H Horse Club members to enhance their overall horsemanship skills by allowing them to demonstrate their learned ability to train and show young horses. Members are to learn training skills by being responsible for the care, fitting and training of the project. Advice and instruction from resource personnel such as parents and professionals in the horse industry is encouraged; however, resource people should be used as teachers, not as participants in the actual training and care of the project. It is intended that the youth are responsible for the daily care, fitting and training of project. For the benefit of the learning experience of the youth, the training project is designed for as much hands-on fitting and training by the youth as possible. The following rules for eligibility are minimal standards that are acceptable under the rules of program.

When and Where:

The Oklahoma 4-H 2-yr-old training class will be held during the State 4-H Horse Show. Date and location for 2025: The State 4-H Horse Show will be held July 10-12 in Chickasha, OK. The 2-year old in training class will be held July 11, with final times to be determined. Horses will need to be at the show mid-day for check-in; more information will be forwarded with specifics as the show time nears.

Eligibility of Participants:

1. Must be a member of 4-H at time of entry date (April 30th), meeting all the membership requirements established by the county program.
2. The horse must be owned solely by the 4-H member, his parents, brother, sister or guardian on or before the time of first nomination. Ownership is defined as registration papers showing ownership by entry date, or a notarized statement of bill of sale for grade horses by the first nomination date. Entry process will require a statement of ownership signed by the 4-H member and parent or guardian.
3. No one, other than enrolled youth, is to show or exhibit the horse after the entry date (April 30).
4. No one is to ride the horse, other than the enrolled youth, after the entry date (April 30).
5. General Rules of Competition for participation at the State 4-H Horse Show as outlined in the 2025 Rules for Oklahoma 4-H District and State Horse Shows will be followed.
6. All youth and parents will be required to sign an affidavit that the eligibility rules will be adhered to; any documented violation will result in loss of payment and removal from the program.

***The 2-yr-old training class horse is an addition to the 4-H member's district and state qualifying show horses except where the 4-H member is using the horse as a regular show horse. There is no qualification through district for this activity.**

Number of Entries Allowed:

Each 4-H member will be allowed to enter one (1) horse. No substitutions or additions will be allowed following the entry deadline. No refunds of entry fees regardless of reason.

Entry Deadline:

The entry procedure will be composed of a payment due on date indicated on current year entry form. You will receive additional information about the event once materials are completed.

Two-Year-Old Combined Rail Class-Showmanship Class Rules and Conditions

All Breeds: Grade or Registered (NO STALLIONS). Horse must not have turned two years of age before January 1 of the current year. For 2025, horses must have been foaled in the year of 2023.

I. Appointments

A. Personal.

(Same as described in Western Judged, Hunter and Showmanship classes in the State 4-H Rules for Horse Shows). Youth are strongly encouraged to use ASTM/SEI approved safety helmets while preparing and participating with the 2-yr-old training project.

B. Tack.

IT IS THE RESPONSIBILITY OF THE CONTESTANTS TO BRING ANY QUESTIONABLE EQUIPMENT TO THE DESIGNATED EQUIPMENT JUDGE PRIOR TO THE CLASS, AS ILLEGAL EQUIPMENT WILL RESULT IN DISQUALIFICATION. General tack requirements as described in Rules for the specific classes, with the following specification: For Riding division: Horses are to be shown in snaffle or hackamore and ridden with two-hands with the following conditions. Horses may be ridden in the style suitable for their type: western pleasure, ranch riding or hunter under saddle and must follow the tack and attire rules specific for those classes. No curb bits are allowed for any riding discipline for the two-year-old training class.

For horses ridden western: Snaffle refers to a smooth ring snaffle bit (conventional O-ring, egg butt, half cheek, full cheek, or D-Ring) with a broken mouthpiece, with ring no larger than 4". The inside of the ring must be free of any attachments that would provide leverage. The mouthpiece should be round, oval or egg-shaped, smooth and unwrapped metal. It may be inlaid, but smooth or latex-wrapped. The bars must be a minimum of 5/16" in diameter, measured one inch in from the cheek with a gradual decrease to the center of the snaffle. The mouthpiece may be two or three pieces. A three-piece, connecting ring of 1¼" or less in diameter, or a connecting flat bar of 3/8" to 3/4" (measured top to bottom, with a maximum length of 2"), which lies flat in the

horse's mouth is acceptable. Optional loose curb strap (leather) attached below the reins is permissible; reins are to be attached above the curb strap. A hackamore may be used in lieu of a snaffle bit. Hackamore refers to a flexible, braided rawhide or leather, or rope bosal, the core of which may be either rawhide or flexible cable. Absolutely no rigid material will be permitted under the jaws, regardless of how padded or covered. The bosal should be properly fitted relative to the horse's size and conformation. Snaffles are to be ridden with split reins; hackamores may use split reins or closed (mecate) rein. Standard, leather or woven, split reins are mandatory with snaffles; hair reins (mecate) are not permitted with snaffle bits but are with hackamores. All entries must be shown with both hands on reins, maintaining light contact with horse's mouth. The rider's hands should be carried near the pommel and not further than 4" out on either side of the saddle horn. Rider's hands must be steady with very limited movement. Rider's hands should be visible to the judge at all times.

For horses ridden huntseat: In reference to bit mouthpieces, nothing may protrude below the mouthpiece (bar). Broken or solid mouthpieces must be between 5/16" to 3/4" in diameter, measured 1" from the cheek and may have a port no higher than 1 1/2". They may be inlaid, synthetic wrapped, including rubber or plastic or incased. On broken mouthpieces only, connecting rings of 1 1/4" or less in diameter or connecting flat bar of 3/8" to 3/4" (measured top to bottom with a maximum length of 2") and which lie flat in the horse's mouth are acceptable. Snaffle bit rings may be no larger than 4 inches in diameter. No fixed reins are allowed. Smooth round, slow twist, corkscrew, single twisted wire, double twisted wire mouthpieces and straight bar or solid mouthpieces are allowed.

C. Horses will be shown in a rail class under saddle first, followed by Showmanship at Halter. Horses and contestants should not be allowed to leave the arena until placings are announced. Each contestant will be allowed up to a total of three (3) "helpers". Helpers will be allowed into the arena at the conclusion of the riding portion. These three helpers will consist of up to one (1) adult helper and two (2) or three (3) youth helpers (4-H age). The duties of the helpers are as follows: To help with the removal of riding equipment from the horse and the arena, to bring and remove grooming equipment, and to handle horse while contestant grooms the horse. At no time will a "helper" be allowed to "warm-up" a horse for the Showmanship portion of the contest. Wheelbarrows, carts or other mechanical apparatuses are prohibited from entering the ring.

2. Class Rules and Routine

The general routine of the class is as follows: The class will be divided into two divisions: Two-handed Rail Performance Class and Showmanship.

A. State 4-H Rules for Western Pleasure/Hunter Under Saddle and Showmanship apply with the following specifications:

In Rail Performance Class, reins should be held in both hands. This is a two-handed class. In showmanship, all attire and tack will be appropriate for Western/Hunter Division. In Showmanship, judges are to place emphasis on the performance of the horse-contestant team. Consideration will be given for grooming status caused by the exhibition in the Rail Performance Class (i.e. sweat, saddle marks, etc. will be discounted.)

B. All entries are first to be shown in the Rail Performance Class division. Number of heats and the need for finals will depend on the number of horses shown. At the conclusion of the Rail Performance Class division, all horses will be untacked and prepared for showmanship in the show ring. A minimum of 15 minutes will be allowed to prepare horses for the Showmanship division. All horses will then be shown at Showmanship.

3. Placings. Combining rankings in the Rail Performance Class and Showmanship divisions as per the State 4-H Horse Show two-judge system will base Placings. If two judges are used in the class, the overall class placing will be determined by use of the following procedures: a.) The top ten rankings in the Rail Performance Class division will be determined by combining the individual Rail Performance Class placing of the judges as per the State 4-H Horse Show two-judge system, with a pre-assigned tie breaker judge, b.) The top ten rankings of the Showmanship division will be determined by combining the individual Showmanship placing of the judges as per the State 4-H Horse Show two-judge system with a different judge pre-assigned as the tie breaker, c.) The Rail Performance Class division ranking and the Showmanship division ranking will be combined to determine the overall class winners, d.) Those contestants ranking in the top ten on both the Rail Performance division and Showmanship division will place over any contestants ranking in the top ten in only one of the division rankings, e.) Any ties for overall class placing resulting from combining the Rail Performance ranking and Showmanship ranking will be broken on the ranking of the Rail Performance division. (Overall winners = winners in Rail Performance combined placing + winners in Showmanship combined placing.)
4. The judge or designated show official(s) has the authority to excuse from competition any horse deemed unsafe and/or out of control. Any horse receiving inhumane treatment while exhibiting may be dismissed from competition and any exhibitor or associated parties guilty of unsportsmanlike conduct, inhumane treatment or misbehavior may be suspended from participation with conditions as described in the general rules of competition for participation in District and State 4-H Horse Shows.

Horsemanship Curricula for Preparation of Projects to Show

The value of showing in 4-H horsemanship events will depend almost entirely on the preparation activities conducted by the 4-H'er with his/her project. Several pieces of curricula are available to guide for horsemanship development. Materials can be obtained with assistance of County Extension Youth Development Educators. Current issues of curricula are available on-line as part of the Oklahoma 4-H Literature on-line offerings. The Oklahoma 4-H Horsemanship Levels Manual contains a series of step-wise tasks intended for all 4-H'ers participating in horsemanship activities. The manual activities require demonstration and evaluation of horsemanship abilities that are the basis for all riding activities. The Oklahoma 4-H Horse Project Member Self-Evaluation Sheets provide formats for member discussion on purpose and conduct of many of the popular horse show classes. These pieces of curricula should be part of year-round activities of those project clubs with goals of exhibiting their projects at horse events.

Two-Year Old Training Project program

Those 4-H-ers with the experience and ability to train young horses may participate in the State 4-H Two Year Old 4-H Horse Training Project program. A competition requiring the 4-H-ers to exhibit their two-year-old project horse in showmanship and western pleasure is held in conjunction with the State 4-H Horse Show. Rules of participation are provided to County Cooperative Extension offices at the beginning of every year.

Conducting 4-H Horsemanship Activities at Horse Events

Non 4-H groups may offer 4-H 'only' classes as part of their activities so to allow 4-H'ers exposure to additional horsemanship activities. Policies and procedures for 4-H events are outlined in Oklahoma State 4-H Publication 103 [A Message for 4-H Families 4-H Membership Policy for \(current year\)](#). The use of 4-H emblem and associated activities are governed by Federal laws and policies and procedures directed the Oklahoma State 4-H office. Approval of 4-H activities, and use of name and emblem by non-4-H groups and individuals should be sought and receive approval prior to the event.

Four-H Hunter and Jumper classes are one type of activities that may be offered in conjunction with other 4-H sponsored horse events. Judging and class rules governing the host site's show will apply to the 4-H classes. It is suggested part or all of the following classes be offered if holding special classes for 4-H:

Working Hunter, Level I (fence heights not to exceed 2 feet, 3 inches)

Working Hunter, Level II (fence heights not to exceed 2 feet, 9 inches)

Jumping (fence heights not to exceed 3 feet)

As host organization will usually supply the judge and facilities, it is important that the exhibitors be directed to the class rules and judging standards that will apply in the entry material. In addition to specific show rules, rules for 4-H classes should mandate that all 4-H'ers must wear properly fastened protective headgear that meets ASTM/SEI standards or equivalent international standards for equestrian use in all over fence classes and when schooling on the show grounds. As is standard with other horse sport associations, riders should follow acceptable hunter class attire including hunt coats, breeches and high English boots. Optional equipment lists should include unrowelled spurs, crops or bats, and standing or running martingales in working hunter and jumping. Allowable use of protective boots and leg wraps for horses are at the discretion of the show committee.



Oklahoma State University, in compliance with Title VI and VII of the Civil Rights Act of 1964, Executive Order 11246 as amended, Title IX of the Education Amendments of 1972, Americans with Disabilities Act of 1990, and other federal laws and regulations, does not discriminate on the basis of race, color, national origin, gender, age, religion, disability, or status as a veteran in any of its policies, practices or procedures. This includes but is not limited to admissions, employment, financial aid, and educational services.

Issued in furtherance of Cooperative Extension work, acts of May 8 and June 30, 1914, in cooperation with the U.S. Department of Agriculture, Robert E. Whitson, Director of Oklahoma Cooperative Extension Service, Oklahoma State University, Stillwater, Oklahoma. This publication is issued by Oklahoma State University as authorized by the Vice President, Dean, and Director of the Division of Agricultural Sciences and Natural Resources.